



**CLIMATE &
CLEAN AIR
COALITION**
TO REDUCE SHORT-LIVED
CLIMATE POLLUTANTS

Lower-GWP Alternatives in Commercial and Transport Refrigeration: An expanded compilation of propane, CO₂, ammonia and HFO case studies





Copyright © United Nations Environment Programme, 2016

This publication may be reproduced in whole or in part and in any form for educational or non-profit purposes without special permission from the copyright holder, provided acknowledgement of the source is made.

The United Nations Environment Programme (UNEP) would appreciate receiving a copy of any publication that uses this publication as a source.

No use of this publication may be made for resale or for any other commercial purpose whatsoever without prior permission in writing from UNEP.

Disclaimer

The designations employed and the presentation of the material in this publication do not imply the expression of any opinion whatsoever on the part of the UNEP concerning the legal status of any country, territory, city or area or of its authorities, or concerning delimitation of its frontiers or boundaries. Moreover, the views expressed do not necessarily represent the decision or the stated policy of the UNEP, nor does citing of trade names or commercial processes constitute endorsement. While reasonable efforts have been made to ensure that the contents of this publication are factually correct and properly referenced, UNEP does not accept responsibility for the accuracy or completeness of the contents, and shall not be liable for any loss or damage that may be occasioned directly or indirectly through the use of, or reliance on, the contents of this publication.

Publication job number: DTI/2015/PA

Acknowledgements

This document has been developed by the United Nations Environment Programme (UNEP) OzonAction Branch as part of UNEP's work programme under the Climate and Clean Air Coalition (CCAC).

This project was managed by the following UNEP OzonAction Branch team:

Shamila Nair-Bedouelle, Head
James S. Curlin, Network and Policy Manager
Ezra Clark, Programme Officer
Ruperto de Jesus, Capacity Building Assistant

This document was researched and written by:

Walid Chakroun, *Department of Mechanical Engineering, College of Engineering and Petroleum, Kuwait University, and ASHRAE Director for Region at Large*

This document was reviewed by:

Canada: **Philippe Chemouny**
Canada: **Marla Desat**
Canada: **Colin McLeod**
Environmental Investigation Agency: **Christina Starr**
Environmental Investigation Agency: **Mark W Roberts**
National Resources Defense Council: **Alex Hillbrand**
shecco: **Klara Skacanova**
US Environmental Protection Agency: **Apurva Dave**
US Environmental Protection Agency: **Cindy Newberg**
US Department of State: **John Thompson**

UNEP would like to thank the CCAC HFC Steering Committee, the author, reviewers and the CCAC Secretariat for their guidance and contributions to this document.

Art direction and design by:

Sue Cowell, Atomo design (first edition)
Aurélie Ek: (first edition design updates)
Graphic Design Unit, United Nations Office at Geneva: (second edition)

Executive Summary

The Climate and Clean Air Coalition (CCAC) adopted a range of activities to initiate action in key countries and within specific sectors to improve understanding of high global warming potential (GWP) HFC use and create incentives to encourage the development and transition to climate-friendly alternatives to high-GWP HFCs. The CCAC Working Group approved funding for various capacity building activities related to low-GWP alternatives to HFCs. One of these activities included the creation of a compilation of case studies on alternatives to HFCs in the commercial refrigeration sector. UNEP DTIE OzonAction worked in cooperation with the CCAC to publish this compilation in 2014.

The present publication comprises an expanded and updated compilation of case studies on lower-GWP energy efficient alternatives and technologies in the commercial refrigeration as well as the transport refrigeration sectors. It provides a number of new commercial refrigeration case studies as well as case studies from the transport refrigeration sector, including alternatives not previously considered in the first volume, to provide better geographical spread and present a more comprehensive overview of lower-GWP alternatives adopted.

This publication comprises two sections. Section 1 on commercial refrigeration, specifically retail food refrigeration firstly provides a brief sector overview and includes six new case studies and the original five case studies. The information is presented in a consistent and structured manner for each case study to allow easy comparison and cross-referencing. These new case studies cover a carbon dioxide (CO₂) / hydrofluoroolefin (HFO) blend cascade system, two different ammonia and CO₂ cascade systems, a CO₂ transcritical system, a propane system, and a retrofit of a centralised direct expansion refrigeration systems from an HFC to a lower GWP HFC/HFO-blend refrigerant. These supplement the original case studies which covered the following technologies: two transcritical CO₂ systems, a CO₂ cascade system with HFC, a chiller using HFO-1234ze system and a Propane system. Section 2 provides an overview of the Transport Refrigeration Cold Food

Chain sector and three case studies on transport refrigeration. These cover two CO₂ systems and a liquid nitrogen system.

Each case study provides information on the type of facility and refrigerant used, an explanation and background is provided of how the transition was decided upon, designed and carried out. Information on performance and economic considerations are also included. Contact details are provided for the reader to seek out more information from the enterprises, as appropriate.

This updated compilation is primarily intended to assist relevant decision makers, especially those in developing countries, in selecting the most appropriate climate-friendly alternatives in both the commercial refrigeration as well as the transport refrigeration sectors.

Introduction

A note on this edition

This booklet presents an expanded compilation of case studies on lower-GWP alternatives in commercial and transport refrigeration and provides an update to the first set of case studies which was published in 2014 by UNEP DTIE OzonAction/CCAC (*Low GWP Alternatives in Commercial Refrigeration: Propane, CO₂ and HFO Case Studies*, available at: www.unep.org/ccac/portals/50162/docs/Low-GWP_Alternatives_in_Commercial_Refrigeration-Case_Studies-Final.pdf).

Section 1 of the booklet provides a number of new commercial refrigeration case studies, including alternatives not previously considered, as well as all the initial case studies from the first compilation. Section 2 provides case studies from the transport refrigeration sector.

The Climate and Clean Air Coalition to Reduce Short-Lived Climate Pollutants (CCAC) is a unique global effort supporting fast actions to mitigate the impacts of short lived climate pollutants, such as black carbon, methane and many hydrofluorocarbons (HFCs) and addressing near-term climate change and air pollution at the same time. The CCAC is a voluntary partnership bringing together over 50 country and Regional Economic Integration Organization (REIO) partners and 61 non-state partners including intergovernmental organisations, representatives of civil society and the private sector.

The CCAC has launched a transformative initiative (entitled *The HFC Initiative, Promoting HFC Alternative Technology and Standards*) for rapid implementation aimed at promoting HFC alternative technologies and standards to significantly reduce the projected growth in the use and emissions of high-global warming potential (GWP) HFCs in coming decades relative to business-as-usual scenarios. The objectives of the initiative are to mobilise efforts of the private sector, civil society, international organisations, and governments to:

- Promote the development, commercialisation, and adoption of climate-friendly alternatives to high-GWP HFCs;
- Encourage the uptake of climate-friendly alternatives that could support national, regional and global poli-

cies or approaches to reduce reliance on high-GWP HFCs;

- Overcome barriers that limit the widespread introduction of these climate friendly technologies, including those related to the establishment of standards; and
- Encourage the responsible management of existing equipment and better designs for future equipment in order to minimize leaks.

The HFC Initiative will help achieve these objectives by improving global understanding of current and projected future use of HFCs, by sharing lessons on the design and implementation of policies to reduce their emissions and use, by addressing barriers, including reforming standards, and by validating climate-friendly technologies in key areas of HFC use or projected growth.

As countries phase out hydrochlorofluorocarbons (HCFCs) under the Montreal Protocol on Substances that Deplete the Ozone Layer, they often need to make choices between high-GWP HFC alternatives and, when available, more climate-friendly alternatives. Depending on the alternatives selected, the increase in HFC emissions could partly offset the climate benefits achieved by the earlier reduction in ozone-depleting substance (ODS) emissions under the Montreal Protocol.

In order to assist in planning and implementing ODS transitions that minimise climate impacts, OzonAction/CCAC has developed this booklet of case studies on lower-GWP energy-efficient technologies that have been adopted in the commercial and transport refrigeration sector as alternatives to replace or avoid high-GWP HFCs. Given that the commercial refrigeration sector has a number of climate-friendly refrigerant alternatives that are already commercialised or near commercialisation in some countries and regions, the booklet presents lessons learned from real cases in commercial refrigeration and aims to stimulate further investigation to enable a smooth transition away from high-GWP refrigerants and assist in the selection of future refrigerants. The case studies

offer information for system purchasers and operators to consider when upgrading or replacing existing equipment with newly designed systems that decrease impacts on the ozone layer and climate change. Even though the majority of cases are from industrialised (Non-Article 5) countries, the information and experiences presented are relevant to all countries to help users, technical managers, consultants, engineers, designers and equipment suppliers in their assessments and understanding of these technologies in order to achieve similar success. The issues discussed in the case studies are primarily related to transitioning to climate-friendly refrigerants and also include innovative technologies, methodologies and concepts which enhances the overall sustainability of commercial and transport refrigeration systems. These examples from end-users can help build confidence in, and illuminate pathways toward, more climate-friendly commercial and transport refrigeration.

SECTION 1: COMMERCIAL REFRIGERATION

A note on Section 1

This section presents six new case studies (case studies 1 to 6) of technologies and approaches of implementation of lower GWP alternatives in the commercial refrigeration sector, specifically retail food refrigeration, not covered in the first volume to provide better geographical spread and present a more comprehensive overview of lower GWP alternatives adopted. In addition, all the initial case studies that were included in the first compilation of Commercial Refrigeration case studies which was published in 2014 in: *Low GWP Alternatives in Commercial Refrigeration: Propane, CO₂ and HFO Case Studies* are included (case studies 7 to 11).

Sector Overview

The commercial refrigeration sector comprises the equipment, technologies and services used to store and dispense frozen and fresh foods at the appropriate temperatures. This sector includes stand-alone or self-contained systems, condensing unit systems, and centralised or 'multiplex rack' systems. According to the 2014 assessment of the Montreal Protocol advisory panel, the Technology and Economic Assessment Panel (TEAP) Technical Option Committee, commercial refrigeration is one of the sectors where the refrigerant demand is the highest for servicing, as a result of the high emission levels of refrigerants from supermarket systems. Also the special report of the Intergovernmental Panel on Climate Change (IPCC)/TEAP¹ indicated that on a global basis, commercial refrigeration is the refrigeration subsector with the largest CO₂-equivalent emissions, representing 40% of total annual refrigerant emissions. These emissions are categorised as direct and indirect emissions. Direct emissions refer to emissions of the refrigerant itself during system manufacturing, operation, and disposal at end-of-life. Indirect emissions refer to the emission of carbon dioxide and other greenhouse gases (GHGs) that result from the energy consumption (usually electricity) of the system over its lifetime. Reducing the leakage rates through better design and installation practices will reduce the direct emissions. As reported by the IPCC, the refrigerant emissions might represent 60% of the total emissions of GHGs resulting from system operation, the rest being indirect emissions generated by power production. A higher Coefficient

of Performance (COP = heat removed/ required work) for the refrigerated system will help in reducing the indirect emissions since the amount of work required to remove the heat will decrease.

Research was conducted to generate a list of potential case studies for consideration taking into account all of the currently available zero- and lower-GWP refrigerants in commercial refrigeration applications, including "natural" or non-fluorinated refrigerants, such as hydrocarbons, carbon dioxide (CO₂), ammonia, and R-290 (propane) as well as the other major category of alternatives comprising man-made chemicals such as the unsaturated HFCs known as hydrofluoroolefins (HFOs) which include R-450A and R-449A. HFOs are a new class of unsaturated HFC refrigerants which have shorter atmospheric lifetimes and lower GWPs when compared to other HFCs. Some criteria such as geographic location, refrigerant used and available information of the proposed applications were taken into consideration when selecting the case studies. These chosen case studies examine energy efficiency benefits of alternatives, as well as cost, safety, availability, maintainability, life expectancy and other sustainable and environmental considerations. Robust technical information was collected in the chosen case studies based on data provided by the source. These case studies also provide a detailed analysis for the system components, methodologies, and controls technology to optimise energy efficiency and continually update with new developments. An overview of the refrigeration cycles that are used in supermarkets is provided below.

The case studies that are covered in this section (Section 1) of the booklet address mainly centralised systems used in supermarket stores, as well as stand-alone units. The technologies presented in these case studies are only some examples of the many available options for zero- and lower- GWP substances, taking into account all design criteria, such as system performance, environmental impact, and cost analysis. The cases presented here focus on CO₂, hydrocarbons and unsaturated HFC refrigerants, and other options

which deploy ammonia and other configurations of refrigerants. Some of the case studies also provide a sustainable holistic approach with state-of-the-art energy design methodologies and tools such as computational models such as simulations techniques as well as computational air flow dynamics (CFD) and lighting simulations. All these refrigerants still have many challenges that should be considered in the design such as their flammability, toxicity, lower efficiencies in some cases, and cost. Balancing the safety, energy efficiency, cost, and environmental impact of refrigerants using a consistent and comprehensive methodology across all refrigerants and system types is essential in assessing alternatives. Good design is also important for reducing refrigerant emissions and preventing refrigerant loss during installation, operation, maintenance, decommissioning and end-of-life disposal. There are also several ways to reduce the refrigerant charge in a supermarket, such as proper piping design, type of condenser used, use of electronic expansion valves, and an efficiently designed distributed system. All these are measures to reduce refrigerant charges and therefore decrease the overall CO₂ footprint of the system.

Types of Commercial Refrigeration Systems

Most supermarkets use centralised direct expansion (DX) systems to chill their products. Typically, these refrigeration systems are charged with 1,360 – 1,815kg of refrigerant and can leak in excess of twenty percent of their charge each year. Commonly used refrigerants include ozone-depleting HCFC refrigerants, often HCFC-22, and blends consisting entirely or primarily of HFCs. Both HCFCs and HFCs are potent greenhouse gases. Fortunately, in recent years there have been advances in refrigeration technology that can help food retailers reduce both refrigerant charges and refrigerant emissions. Below is a general description of a centralised DX system as well as an overview of the different advanced refrigeration options.

- Centralised DX System

- Distributed System
- Secondary Loop System
- Transcritical CO₂ system
- Cascade System

Schematic of a Centralised DX System

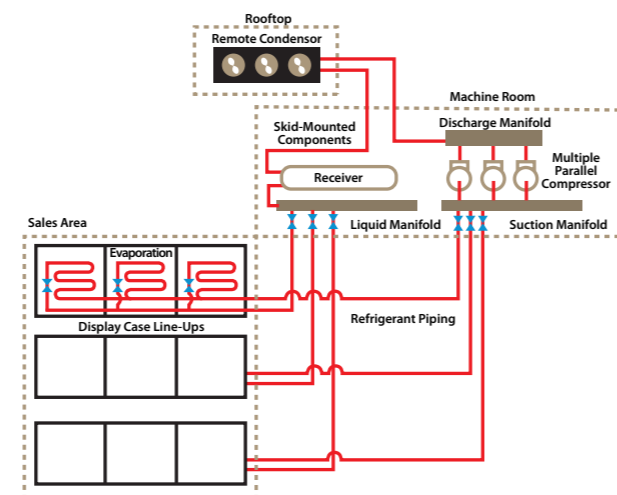

Source: International Energy Agency (IEA). 2003. "IEA Annex 26: Advanced Supermarket Refrigeration/Heat Recovery Systems, Final Report Volume 1-Executive Summary"

Centralised Direct Expansion System

A large number of supermarkets use centralised DX systems to cool their display cases and walk-in refrigerators. In a DX system, the compressors are mounted together and share suction and discharge refrigeration lines that run throughout the store, feeding refrigerant to the cases and coolers. The compressors are located in a separate machine room, either in the back of the store or on its roof, to

Schematic of a Distributed System

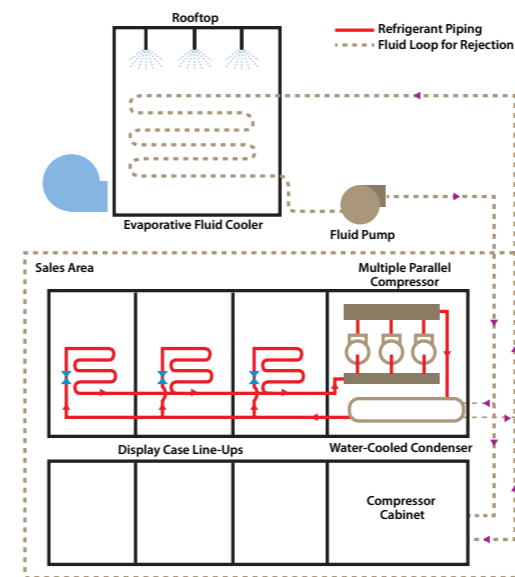

Source: International Energy Agency (IEA). 2003. "IEA Annex 26: Advanced Supermarket Refrigeration/Heat Recovery Systems, Final Report Volume 1-Executive Summary."

reduce noise and prevent customer access, while the condensers are usually air-cooled and therefore placed outside to reject heat.

The multiple compressor racks operate at various suction pressures to support display cases operating at different temperatures. The hot gas from the compressors is piped to the condenser and converted to liquid. The liquid refrigerant is then piped to the receiver and distributed to the cases and coolers by

Schematic of a Secondary Loop System

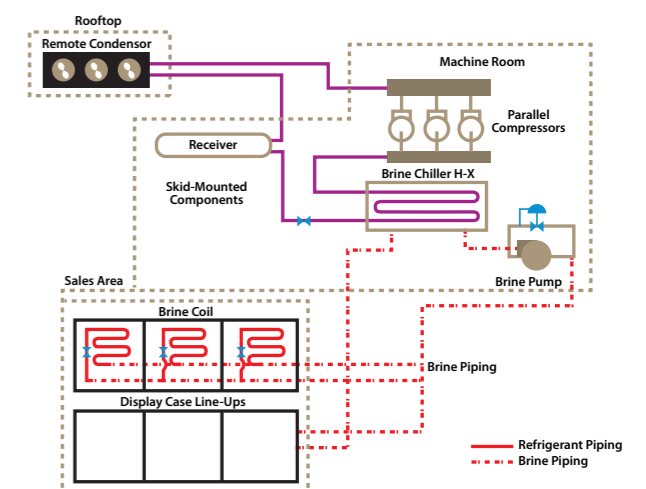

Source: Southern California Edison and Foster-Miller, Inc. 2004. "Investigation of Secondary Loop Supermarket Refrigeration Systems." Report prepared for California Energy Commission, Public Interest Energy Research Program.

the liquid manifold. After cycling through the cases, the refrigerant returns to the suction manifold and the compressors. Supermarkets tend to have one DX system for low-temperature refrigeration (e.g., ice cream, frozen foods, etc.) and one or two DX systems for medium temperature refrigeration (e.g., meat, prepared foods, dairy, refrigerated drinks, etc.).

Distributed System

Unlike centralised direct expansion refrigeration systems, distributed systems use multiple smaller units that are located close to the display cases that they serve. For instance, compressors in a distributed system may be located on the roof above the cases, behind a nearby wall, or even on top of, or next to, the case in the sales area. The close proximity of the compressors to the cases and coolers allows the system to use less piping and a smaller refrigerant charge than traditional DX systems. This reduction in charge often results in a decrease in total refrigerant emissions.

Secondary Loop System

Secondary loop systems use a much smaller refrigerant charge than traditional direct expansion refrigeration systems, and hence have significantly decreased total refrigerant emissions. In secondary loop systems, two liquids are used: a primary refrigerant and a secondary fluid. The secondary fluid is cooled by the primary refrigerant in the machine room and then pumped throughout the store to remove heat from the display equipment. Secondary loop systems typically operate with two to four chiller systems depending on the temperatures needed for the display cases.

Transcritical CO₂ system

Refrigeration systems that use CO₂ as a primary refrigerant are commonly referred to as transcritical CO₂ systems. In transcritical CO₂ refrigeration systems CO₂ is the sole refrigerant, evaporating in the subcritical region and rejecting heat at temperatures above the critical point in a gas cooler instead of a condenser. In addition to having a simple concept, this system has considerable environmental benefits in terms of reducing HFC usage completely.

Cascade System

Cascade systems consist of two independent refrigeration systems that share a common cascade heat exchanger. Each of the two systems uses a different refrigerant that is most suitable for a specific temperature range. High temperature systems use high boiling point refrigerants such as R-404a, R-507a, R-134a, propane, butane, and ammonia, whereas low temperature systems use low boiling refrigerants such as R-744 (CO₂) and R-508B. The advantages of a cascade system include a reduction in the refrigerant charge and a reduced carbon footprint.



CASE STUDY-1

Auchan – City center mall, France

Name of the Store/facility:

Auchan – City center mall

Location:

Epinau sur-Seine, France

Contact information:

Name: Robert Kebby

Email: robert.kebby@honeywell.com

Designation: Global Marketing Manager – Commercial Refrigeration

Type of Facility:

New build Hypermarket, Area: 8000m²

Refrigeration System type: Centralised packaged CO₂ / Solstice® N13 R-450A Cascade refrigeration system

Refrigerant Used:

The store was originally planned to use HFC-134a / pumped Carbon dioxide (CO₂) Cascade system where HFC-134a has a Global Warming Potential (GWP) of 1430. The decision was made to use Solstice® N13 (R-450A) - a lower GWP hydrofluoroolefins (HFO) blend from Honeywell - in place of HFC-134a in the store. Solstice® N13 (R-450A) is a Zeotropic blend of HFC-134a and HFO-1234ze (Solstice® ze). (42% HFC-134a / 58% R-1234ze). Solstice® N13 is A1 and has a GWP of 547: a near 62% reduction (883) in the GWP level of R134a with an expected, slight 3% Co-efficient of Performance (COP) improvement validated by independent party laboratory testing (Tewis Smart Solutions International).

Project Background:

Groupe Auchan has a preferred refrigeration design they use on their larger format stores. This system has been designed to minimise refrigerant leakage, reduce the energy consumed, whilst ensuring progress towards lowering their CO₂ footprint.

The store was a totally new build 'flagship' store for Auchan on the outskirts of Paris. Fig.1 shows a photo of the hypermarket in Paris. Ability to maintain the same system design was key to allowing the Axima technicians an easy introduction to the use of this new HFO blend.



Fig. 1 Auchan Hypermarket, Paris

The system in operation showed a slight improvement in performance, a lower condensing temperature than HFC-134a and reduced oil temperature – meaning less 'wear and tear' on the compressors / longer system life. Pressures, saturated temperatures and mass flow of the refrigerant Solstice® N13 was very similar to that of HFC-134a.

New System/Installation:

Groupe Auchan worked alongside its refrigeration partner Axima Refrigeration to develop a more environmentally conscious system for the Epinau sur-Seine store that combined the lower GWP and slightly better energy efficiency of a new refrigeration HFO blend named Solstice® N13 – and the proven performance of pumped CO₂. Solstice® N13 has a critical temperature of 104.4 °C and critical pressure of 38.2 bar.

The system uses Solstice® N13 in a liquefaction unit to convert gaseous CO₂ into a liquid that is then pumped to deep freeze containers, cold rooms and display cabinets. The CO₂ returns in a gaseous form to the Solstice® N13 liquefaction unit ready for converting again to liquid. Table 1 shows Medium and Low Temperature system details.

DESCRIPTION	MEDIUM TEMPERATURE	LOW TEMPERATURE
Refrigerant	Solstice® N13 (R-450A)	CO ₂
Refrigerant charge	1,200 kg	Secondary MT circuit = 2,000 kg
LT Cascade circuit = 2,000 kg		
Refrigeration power	800 kW	105 kW
Consumption power	350 kW	21 kW
Regime (evap. /condensing temp)	-11°C / +45°C	-45°C / +35°C
Compressor type and manufacturer	Screw / Bitzer	Semi-Hermetic Piston / Bitzer
No. of compressors	6 in 2 packs	3 in 1 pack

Table 1 Medium and Low Temperature system details

All components used for the Solstice® N13 system were pre-approved by manufacturers to ensure consistent operation.

To support the yearly energy saving objectives of the project, the system includes a floating high pressure, a floating low pressure, as well as variable speed control on the compressors of the negative CO₂ rig, on the positive N13 compressor and on heat recovery units. Fig. 2 shows a schematic diagram of the refrigeration system.

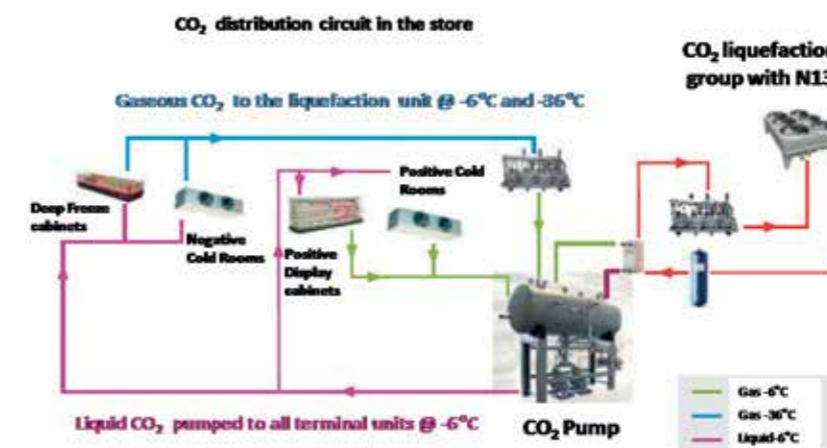

Fig. 2 Schematic Diagram of the Refrigeration System

Field Test Results: Proving the Value of Solstice® N13 (R-450A)

Commissioning was easy and straightforward and standard polyol-ester (POE) oil used for HFC-134a was suitable for compressors. The Solstice® N13 liquefaction rig started as it would have done with HFC-134a (insignificant glide as it is a zeotropic blend of HFC-134a and HFO-1234ze, slightly lower pressure than HFC-134a).

Since the opening of the Auchan Epinay store in October 2013, a thorough evaluation of the results by the entire project team confirmed the energy efficiency benefits of the trial; the energy consumption of the Solstice® N13 / CO₂ system is slightly less (3%) than the expected energy consumption of the standard Groupe Auchan HFC-134a / CO₂ system. Fig.3 shows a photo of the system installation.

The new system was also measured against the following criteria to ensure the resulting performance was as good if not better than the current design:

- Discharge temperature at compressor head 110°C (Below that of HFC-134a systems)
- Compressor Oil temperature 55°C (Below that of HFC-134a systems)



Fig. 3 System Installation of the Refrigeration System

Performance:

The test focused on assessing the merits of a system that incorporated an N13 liquefaction unit alongside a CO₂ refrigerated distribution circuit.

As initially dimensioned on HFC-134a, only sanity checks were necessary to assess the capacity match with Solstice® N13. An 8% extra capacity was theoretically needed, but as the system was already oversized to anticipate future store extensions, no modifications were required.

Solstice® N13 was also positively seen, by Auchan and by the contractor Axima, as a safe and simple direct HFC-134a alternative. Being non-flammable, non-toxic and experiencing lower pressures than HFC-134a turned all the flags to green.

When the system was commissioned, Solstice® N13 was a few months from commercial availability worldwide, so a full charge of product was made available on site in case of a catastrophic leakage. It went commercial a couple of months later and is now fully available in the distribution network. In between, the main component manufacturers (for compressors, controls, etc.) released qualified product ranges to enable spreading the technology.

The system was finally compared with Auchan's current standard set-up that uses HFC-134a and glycol water with CO₂. The results to date have been encouraging, and include:

- Easy commissioning, with similar expected electricity consumption as HFC-134a (no monitoring).
- A global saving of 90 tons CO₂ eq / year compared with a secondary Glycol /HFC-134a / CO₂ system and savings of 960 tons CO₂ eq / year compared with using a standard HFC-404A DX system.

The system was commissioned in October 2013 and has been running without issue since.

Cost and Economic Considerations:

The cost of the new system is almost same as original HFC-134a design. Maintenance cost is expected to be same or less due to the lower operating pressures of the system when compared to HFC-134a. Also, less work for compressors due to lower pressures and improved efficiency for Solstice® N13 over HFC-134a. Other tests and trials conducted at Honeywell R&D laboratories, and in laboratories and supermarkets in various European countries by an independent energy consulting company (Tewis), have shown up to 3% reduction in energy consumed when compared directly against R-134a. The refrigerant cost for Solstice® N13 is slightly higher than HFC-134a – due to the HFO blend. (Solstice® ze is a major portion of the blend).

Disclaimer:

The information presented here is provided by Groupe Auchan. The accuracy of the content and figures is the responsibility of the company and these have not been verified by the CCAC or UNEP.

CASE STUDY-2

Pick'n'Pay stores, South Africa

Name of the Store/facility:

Pick'n'Pay stores, South Africa

Location:

"Strand" Store: Fagan Street, Strand, 7140, Western Cape (Cape Town Area)

"Rand Park Ridge" Store: Rand Park ridge Mall, Cnr John Vorster & Ferero Str, Rand-Park ridge, 2156, Gauteng (Johannesburg Area)

Contact information:

Name: Bernhard Siegele

Email: bernhard.siegele@giz.de

Designation: GIZ Proklima Programme Manager

Type of Facility:

Two Supermarkets:

Trading area for store at Strand: 1800 m²

Trading area for store at Rand Park Ridge: 2300 m²

Refrigeration System type: Cascade system

Technology Transition:

Transition from HCFC-22 systems to cascade refrigeration systems, using a combination of ammonia (R-717; NH₃) and carbon dioxide (CO₂) systems. Refrigerant previously used was HCFC-22 which has a Global Warming Potential (GWP) of 1780. New refrigerants used are ammonia and CO₂, which have GWPs of 0 and 1 respectively.

Refrigerant Used:

The new refrigeration system runs with ammonia in the compressors and uses a heat transfer medium for the distribution into the cold rooms and cabinets in the trading area. A CO₂ cascade provides the temperatures needed for the freezer cabinets.

Project Background:

Pick'n'Pay is a leading food retailer in South Africa. With about 700 stores and 2,000,000 m² retail space as of 2012, it holds 30% of the total market share. As South African based supermarket chains were invited to participate in a project that aimed at installing a pilot refrigeration system using only natural

refrigerants, Pick'n'Pay was determined to be the most committed and relevant. This project was carried out under the International Climate Initiative (IKI) of the German Federal Ministry for the Environment, Nature Conservation, Building and Nuclear Safety (BMUB). Fig. 1 shows photos of Pick'n'Pay stores.



Fig. 1 Photos of Pick'n'Pay Stores



The original systems in both supermarkets were similar in their design as well as in their shortcomings. Both systems were centralized, direct expansion systems, with a refrigerant charge at or above 1000 kg in both cases. The piping was installed within the walls and floors, making it impossible to detect and repair leakages.

In the supermarket in Strand, this resulted in very high leakage rates of about 80 % annually, thereby emitting more than 1400 t CO₂eq annually due to refrigerant loss alone, based on a charge of 1000 kg HCFC-22. One reason identified for this extremely high leakage rate

was the defrosting of the cabinets via hot gas. Although it is an energy-efficient way of defrosting, the process involves high pressure and temperature changes, which can weaken the joints and piping. Condensing temperatures were also fixed on a high level, leaving saving potentials due to lower ambient temperatures untapped. Required condensing temperatures are dependent on ambient temperatures and the type of heat exchanger to enable the heat transfer from the system into the ambient air. For every (unnecessary) degree exceeding this required difference, the compressor consumes about 2-3 % more energy.

The refrigeration system in the supermarket in Rand-park Ridge had a lower, but still considerable leakage rate of 30% annually, with a charge of 1200 kg HCFC-22. This caused more than 600 t CO₂eq of emission per year. Installed cooling capacity was 140 kW medium temperature and 60 kW low temperature. Energy consumption was not metered, but the calculated COPs were 2.52 for medium temperature and 1.32 for low temperature. Cooling cabinets were deploying an electric defrosting cycle four times a day, which needed high energy input and damaged the stored goods.

The preparations for the system replacements started in 2008 with field visits performed in cooperation with a Europe based consulting firm experienced in natural refrigerant application in supermarkets. Based on the evaluations during this field visit, propane was ruled out due to higher safety precaution needed for the existing machinery rooms in the basements. There was no possibility for an open air setting for the propane using components. The selected option of Ammonia with a CO₂ cascade for low temperature was also evaluated to be the best solution for the climatic conditions. One site is located in Johannesburg and the other in Cape Town. Temperatures are generally higher in Cape Town, reaching up to 40 °C.

One major focus of the project was building local capacity to ensure proper maintenance as well as further replication and development of these new technologies. Local engineering firms were

commissioned for the project and the refrigeration systems were engineered and manufactured locally. Installation started in 2009 and corresponding training for technicians on the safe handling of Ammonia and CO₂ was also carried out. By spring 2010, the new systems were fully operational. In addition to the performed conversions, an extensive energy management system was also developed in the course of the project, which allowed Pick'n'Pay to monitor their energy consumption and make corresponding adjustments where needed.

New System/Installation:

In the store in Rand-park Ridge, there are 44 cabinets for medium temperature products and 18 for frozen goods. This adds up to 172 meters of refrigeration displays and 204 m² of cooled display area. There are also 230 m² of cold rooms for storage and a 72 m² butchery preparation area. The ammonia compressor rack was sourced from GEA Grasso: a 3x310 chiller package with an ammonia charge of 150 kg. The CO₂ compressor is manufactured by the Australian company eCO₂ Technologies and contains 70kg CO₂. Fig. 2 shows the installation of 3 x 310 Chiller package at Pick'n'Pay store in Rand-park Ridge.



Fig. 2 GEA Grasso 3x310 chiller package in Pick'n'Pay store at Rand Park Ridge



Fig. 3 CO₂ compressor in Pick'n'Pay store at Strand

refrigerated food stuff (this increased stability is a result of the lower temperature fluctuations of the glycol loop and higher surface temperatures of the heat exchangers inside the cabinets that lead to higher air humidity)

- fewer defrost cycles necessary
- secondary loop can be constructed in plastic piping and fittings which may be cheaper than copper piping traditionally used with direct expansion systems

Performance:

The energy performance was monitored and compared to samples of other stores located in the same climatic region. The methodology was adopted from the German supermarket Quick-Check tool, developed by VDMA (Verband Deutscher Maschinen- und Anlagenbau, German Engineering Federation): The reference parameter is the cooled display area installed in the store (i.e. the area of the openings of all display cabinets). In this way, differently sized supermarkets can be compared.

There was no direct comparison undertaken between the old and the new system, because the condition of the old systems was far beyond what is considered as "state of the art". Instead, comparisons of energy efficiency were made between the installed natural refrigerant systems and other state-of-the-art direct expansion systems using synthetic refrigerants.

The monitoring results for two years showed clearly that energy efficiency is higher for the natural refrigerant systems. Energy savings are on average about 13% for Strand and 21% for Rand-Park Ridge. The charts below show the average consumption of the project stores in comparison to the other stores in the corresponding area and demonstrate a clear advantage in the project stores. The charts also reveal that as technological development continues, the specific energy consumption of an average store decreases constantly. This was achieved through improved components and control systems – a development that can be observed with both synthetic and natural

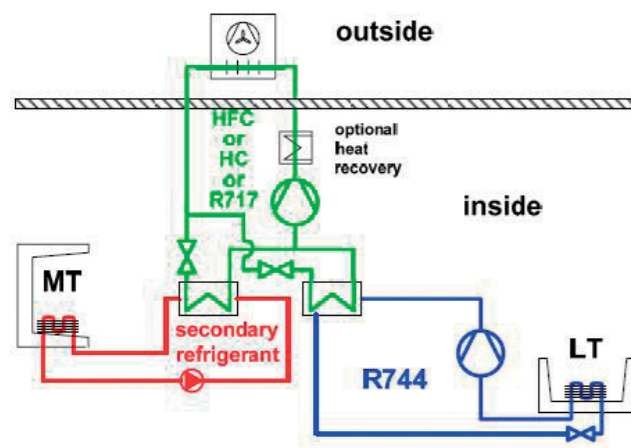

Fig. 4 Schematic drawing of an indirect refrigeration system with a CO₂ cascade. Source: M. Kauffeld, University of Applied Science, Karlsruhe

The indirect system with propylene glycol as heat transfer medium has a number of advantages compared to conventional direct expansion systems such as the following:

- reduced primary refrigerant charge (since the refrigerant remains inside the machinery room)
- higher quality and lower risk for leaks due to factory assembly of the primary refrigeration system
- possibility for using flammable or toxic refrigerants because refrigerant does not circulate inside the store area
- more stable levels of air temperature and humidity in display cases and therefore less shrinkage of the

refrigerants. It should also be noted that these were pilot installations in South Africa, which require system settings for optimum energy efficiency to be continually updated with new developments. Fig. 5 shows the Energy consumption of Pick'n'Pay store at Strand, Cape Town and Fig. 6 shows the Energy consumption of Pick'n'Pay store at Rand-park Ridge, Gauteng.

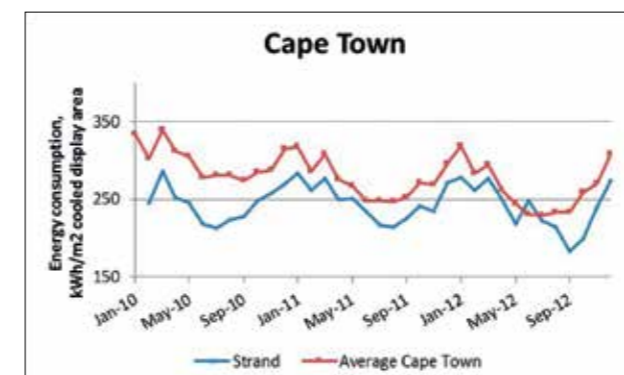

Fig. 5 Energy consumption of the store in Strand, compared with the average of Cape Town (Calculated by GIZ Proklima)

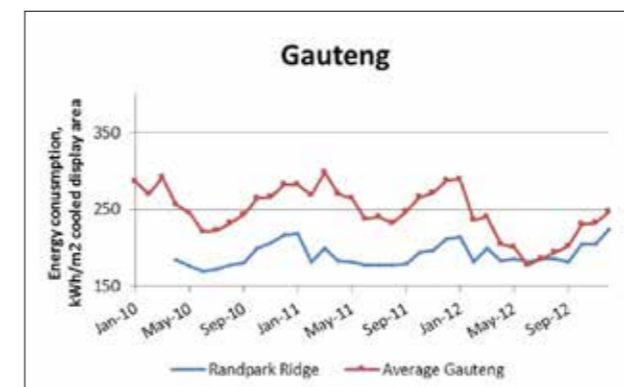

Fig. 6 Energy consumption of the store in Rand Park Ridge, compared with the average of Gauteng region (Calculated by GIZ Proklima)

It was ensured that the systems would meet European standards EN 378 through safety and quality checks by the German TÜV.

It was the first indirect system to be built in a supermarket in South Africa. Presently, quite a few new supermarkets are choosing to use indirect systems using CO₂ in a cascade for low temperature.

Cost and Economic Considerations:

The installation cost for these two pilot plants were considerably higher than the existing market prices at the time. This price difference can be explained by the pilot character of the project in South Africa. An exact overview of the market would be necessary to evaluate current prices, but it can be assumed that the installation of both systems have decreased in cost and are comparable to synthetic refrigerant systems, when considering investment and operating costs.

With an assumed extra cost of 30% compared to a conventional system, a payback period of 7 years can be expected – taking the rising electricity prices announced in South Africa into account. Given a higher expected system life time of up to 30 years for the ammonia system compared to conventional direct expansion systems, this also increases the economic feasibility of the systems. Additionally, the systems were pilots venturing into new design and type of systems, built by local engineering offices and manufacturers. Therefore both systems were hugely over-designed. Consequently optimisation works and cost-reduction measures would lead to significant increase of economic feasibility. Maintenance costs for natural refrigerant systems and conventional systems are comparable while some savings of up to 4000 to 5500 ZAR (South African Rand) annually per natural refrigerant system could be achieved due to lower cost for refrigerant refill.

Disclaimer:

The information presented here is provided by Pick'n'Pay. The accuracy of the content and figures is the responsibility of the company and these have not been verified by the CCAC or UNEP.

CASE STUDY-3

Lackland Air Force Base Commissary, USA

Name of the Store/facility:

Lackland Air Force Base Commissary

Location:

San Antonio, Texas, United States

Contact information:

Name: John Stuit

Email: john.stuit@deca.mil

Designation: Chief of Design and Construction

Type of Facility:Commissary, Store Area: 10,870 m²

Refrigeration System type: Cascade system

Technology Transition:

Transition of centralized system from HFC-404A (a hydrofluorocarbon (HFC) blend consisting of 44% HFC-125, 52% HFC-143a, and 4% HFC-134a) direct expansion system to an ammonia (NH₃)/carbon dioxide (CO₂) cascade system. Refrigerant previously used was HFC-404A which had a Global Warming Potential (GWP) of 3900. New refrigerants used are ammonia (NH₃) and CO₂, which have GWPs of 0 and 1 respectively.

Refrigerant Used:

Ammonia/Carbon Dioxide

Project Background:

The commissary in San Antonio, Texas is 10,870 m². The store is located in the community service area of the Lackland Air Force Base and is surrounded by other retail stores, banks, schools, and housing. Fig. 1 shows the photo of Lackland Commissary.



Fig. 1 Outside the Lackland commissary. Photo courtesy of CTA Architect Engineers.

The previous refrigeration system contained more than 7,000 pounds (\approx 3200 kg) of HFC-404A—a greenhouse gas refrigerant blend with a global warming potential (GWP) of 3,922². Based on an annual average leak rate of roughly 8.5%³, the system leaked more than 600 pounds of refrigerant each year—equivalent to roughly 1,100 metric tonnes of CO₂. The system was over 13 years old and was ready for retirement.

The NH₃/CO₂ cascade system that has been installed at the Lackland commissary consists of three key pieces: (1) an NH₃ direct expansion system, (2) a CO₂ secondary loop system, and (3) a CO₂ direct expansion system. The NH₃ system, which is contained in an outdoor enclosure on the roof of the building, relies on a condenser water loop to connect the NH₃ compressors with the evaporative fluid cooler, and is used to condense vapor CO₂ into a liquid. The liquid CO₂, which is stored in a tank adjacent to the NH₃ system, is circulated throughout the store to remove heat from both the low and medium temperature cases. On the medium temperature side, the liquid CO₂ passes through a coil to remove heat from the refrigerated space and then returns directly to the liquid CO₂ tank prior to being condensed again by the NH₃ system (utilizing a secondary loop design). On the low temperature side, the liquid CO₂ first passes through an expansion valve, evaporates into a gas as it removes heat from the refrigerated space, and then is compressed prior to returning to the roof.

In total, the system has a low temperature cooling capacity of 304 thousand British Thermal Units per hour (MBTUs/hr) and a medium temperature cooling capacity of 1,233 MBTUs/hr. The system consists of nine ammonia modules, each containing nine pounds of refrigerant, for a total of 81 pounds of NH₃ as well as roughly 1,800 pounds of CO₂. To increase energy efficiency, LED lighting is used in all refrigerated cases and cold storage rooms. Additionally, display cases with glass doors are used for the majority of products (except produce and fresh meat).

New System/Installation:

With help from Hillphoenix and CTA Architect Engineers, the Defense Commissary Agency (DeCA) replaced the old refrigeration system with an ammonia (NH₃)/carbon dioxide (CO₂) cascade system, which uses a refrigerant with a negligible GWP. The store remodel, which is being implemented by Summit Construction, began in January 2014 and is expected to be completed by August 2015, during which time the store has remained open to the public. The installation of the refrigeration system was completed in December 2014. As part of the remodel, all cases, piping, controls, and the HVAC system are also being replaced.

DeCA chose to adopt a NH₃/CO₂ cascade system for two main reasons: (1) to control future capital and operating costs, and (2) to meet the energy and sustainability goals the U.S. Government has established for all public buildings⁴.

Prior to their decision, DeCA reviewed the possible refrigeration systems that could be used to meet their goals. DeCA wanted to use a refrigerant with low or no GWP to eliminate climate risk and address the regulatory uncertainty around climate policies, which could impose future penalties on the use or emissions of high-GWP refrigerants or even force a refrigerant conversion. DeCA also wanted to adopt a system that is more energy efficient than standard industry rack systems that typically use R-404A refrigerant, and eliminate safety concerns. They also aimed to adopt equipment that can be easily serviced and wanted to keep costs reasonable.

With these criteria in mind, DeCA considered installing either a transcritical CO₂ system or an NH₃/CO₂ cascade system. Due to the hot climate of southern Texas, the NH₃/CO₂ cascade system was deemed the most suitable choice for the Lackland Air Force Base commissary⁵.

The greatest challenge DeCA faced in implementing the NH₃/CO₂ cascade system at the Lackland commissary was public acceptance of using NH₃ in a building near sensitive areas, such as day care facilities and schools. To address this concern, the National Renewable Energy

Lab (NREL) and the Environment Protection Agency (EPA)—with technical assistance from CTA Architects Engineers and Hillphoenix—conducted an ammonia plume study, which analyzed the potential effects of ammonia being released from the system into the community. Results of the study showed that the system poses minimal threat to human health, with impacts mainly limited to short-lived unpleasant odors. The risk of public health impacts can be mitigated through the use of a continuous leak monitoring system. In addition to conducting the study, DeCA also conducted public outreach to community leaders to effectively communicate the results of the study and alleviate concerns. While DeCA is confident that concerns over the use of NH₃ will fully dissipate, a key lesson learned is the need to actively engage the community from the start in order to proceed with an ammonia system.

Other key lessons learned include the need to prepare maintenance teams and maintain spare parts on hand. For instance, because the NH₃/CO₂ cascade system is designed differently than conventional systems, DeCA's personnel must be trained on how to service and maintain them. To address this important issue, Hillphoenix will conduct training sessions over the course of several days to educate DeCA maintenance teams on how to handle the system. These training sessions are incorporated into the Hillphoenix service contract. In addition, DeCA recommends having spare system components on hand (e.g., ammonia compressor) to allow for timely repairs, since parts delivery may take several days until the technology is more widely in use. As more NH₃/CO₂ cascade systems are adopted across the United States and more technicians are trained on how to service these systems, personnel training and component availability will pose less of a challenge for users. Fig. 2 shows a Schematic diagram of NH₃/CO₂ cascade system to be installed at the Lackland commissary.

² Meaning that it is 3,922 times more damaging to the climate system than CO₂ on an equal mass basis.

³ Based on the average leak rate of the existing R-404A system during 2012 and 2013.

⁴ Federal mandates (i.e., Executive Order 13423 on Strengthening Federal Environmental, Energy, and Transportation Management, as well as the Energy Policy Act of 2005) require that energy consumption be reduced by 30% in new buildings and 20% in remodelled buildings.

⁵ According to DeCA analysis, transcritical CO₂ systems are the preferred option for use in cooler climates.

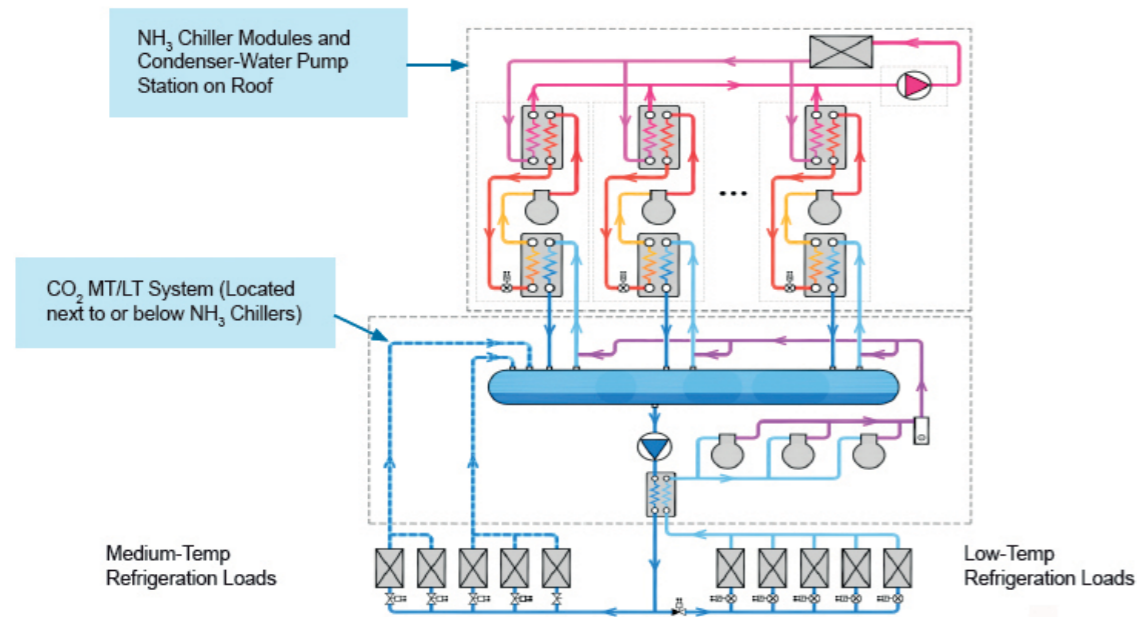

Diagram of the NH₃/CO₂ cascade system to be installed at the Lackland commissary. FMI Energy & Store Development Conference presentation, September 2012, Phoenix, Arizona.

Fig.2 Schematic Diagram of the NH₃/CO₂ cascade system to be installed at the Lackland commissary. Food Marketing Institute (FMI) Energy & Store Development Conference presentation, September 2012, Phoenix, Arizona.

Performance:

Compared to the existing R-404A rack system, it is expected that compressor energy use of the new system will be reduced by 8%, resulting in a system-wide energy reduction of roughly 3%.

DeCA anticipates adopting NH₃/CO₂ cascade systems as the standard technology at other commissaries located in warm climates. NH₃/CO₂ cascade systems will also be considered for installation in other types of facilities such as DeCA's cold storage and central distribution center at Sagami General Depot in Japan. In addition, transcritical CO₂ systems will be considered for use at commissaries in cooler climates, such as at the facility at the U.S. Air Force Base in Spangdahlem, Germany and in the commissary in Newport, Rhode Island⁶. Worldwide, there are approximately 250 U.S. commissaries.

Cost and Economic Considerations:

Upfront costs of the NH₃/CO₂ cascade system were more than \$2.5 million, roughly 15% higher than a standard system—an incremental cost of roughly \$300,000. Refrigerant costs are expected to be over 90% lower than the previous system. Maintenance costs are also expected to be almost 40% lower. Overall, operational savings from energy use, refrigerant use, and maintenance costs are expected to offset the incremental capital cost, resulting in only a small net cost increase over the estimated 20-year lifetime of the system. Once the technology reaches large scale commercialization, it is expected that the life cycle cost of future systems will be equal to or less than a typical R-404A rack system.

Disclaimer:

The information presented here is provided by Lackland AFB. The accuracy of the content and figures is their responsibility and these have not been verified by the CCAC or UNEP.

⁶ Construction began at the Spangdahlem commissary in February 2014. The new commissary, which will use a transcritical CO₂ refrigeration system, is expected to be complete by the spring of 2016.

CASE STUDY-4

Alfamidi Convenience Store, Indonesia

Name of the Store/facility:

Alfamidi Convenience Store, Indonesia

Location:

Various locations in Jakarta, Indonesia

Contact information:

Name: Hiroyuki Matsutani
 Email: hiroyuki.matsutani@lawson.co.jp
 Designation: Technical Issues Energy Conservation and Recycling Promotion Dept.
 Franchisee Operation Support Division

Name: Ming Li
 Email: ming.li@lawson.co.jp
 Designation: Technical Public Relations department, Lawson, Inc

Type of Facility:

Convenience Store, Area: 260m² (approx.)
 Refrigeration System type: Transcritical direct expansion systems

Technology Transition:

Transition from HCFC-22 systems to CO₂ systems.
 Refrigerant previously used was HCFC-22 which had a Global Warming Potential (GWP) of 1780. The new refrigerant used is CO₂, which has a GWP of 1.

Refrigerant Used:

Low GWP Refrigerant: CO₂
 CO₂ is a natural refrigerant, non-toxic and non-flammable.

Project Background:

"Alfamidi", is a convenience store operated by PT MIDI UTAMA INDONESIA Tbk (Hereinafter referred to as MIDI). MIDI is an Indonesian company allied with Lawson. Most of the stores considered in this case study were opened in the year 2014-2015. A photo of Alfamidi store is shown in Fig. 1.



Fig. 1 Photo of Alfamidi Store

As a general configuration at Alfamidi, there are 3 reach-in showcases with 6 feet width display area and there is an open showcase with 6 feet width. There are several manufacturers supplying these showcases above, and the manufacturer varies at each store as shown in table 1.

No.	Manufacturer	Equipment Name	Model No.	Store Before Replacement
1	Panasonic	GLASS CHILLER	SRM-P3DBMR	Alfamidi Suryadarma Alfamidi Palmerah Utara
2	Sanden	OPEN CHILLER SHOWCHASE	SON-1800SAX	Alfamidi Suryadarma Alfamidi Muncang Alfamidi Raya Tengah Alfamidi Tebet Timur Dalam Alfamidi Matraman Raya Alfamidi Ceger Raya 2 Alfamidi Palmerah Utara Alfamidi Meruyung
3	Sanden	Display Cooler (glass door)	SDC-1500AY	Alfamidi Muncang Alfamidi Raya Tengah Alfamidi Raya Tengah Alfamidi Tebet Timur Dalam Alfamidi Matraman Raya
4	Sanden	GLASS CHILLER TYPE	SDC 1000AY	Alfamidi Raya Tengah
5	Starcool	Island Freezer	SD-750	Alfamidi Raya Tengah
6	AHT	Freezer	Paris 210/185	Alfamidi Raya Tengah
7	AHT	Freezer	Salzberg 210	Alfamidi Muncang
8	Rebecca	Freezer	Rebecca TC - 200	Alfamidi Muncang

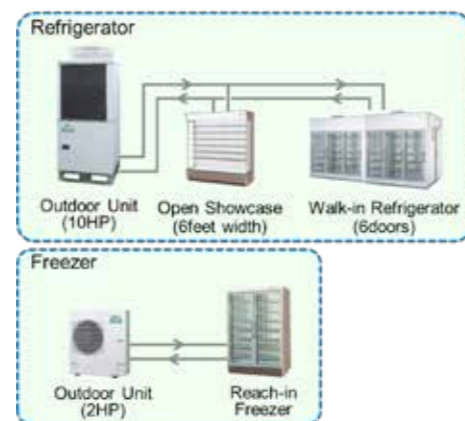

Fig. 2 Schematics of Refrigeration Systems used in Alfamidi stores

There are two separated centralized remote refrigeration systems for refrigeration and freezing at each store. They are transcritical, direct expansion systems. Fig. 2 represents a general schematic of Refrigerant systems used in Alfamidi stores.

In Japan, the enforcement of amended "Fluorocarbons Recovery and Destruction Law" started in April 2015. It is required to control the refrigerant leakage for refrigeration system users. So, Lawson started to build the organization to do it. There is no such a law or legislation in Indonesia but MIDI voluntarily install CO₂ refrigeration systems there. The first reason is GWP of CO₂ is 1, much less (approx. 1/1,800 compared to R22) than HCFCs or HFCs, the second reason is CO₂ refrigeration system can reduce energy consumption by approx. 18% compared to HCFC-22, and this reduction corresponds to 6% of total store energy consumption. Installing CO₂ refrigeration system can reduce global warming impact almost by half including the direct effect and indirect effect.

There are two projects, both Japanese government funded Joint Crediting Mechanism (JCM) related, one is from Ministry of Economy, Trade and Industry (METI), JCM feasibility study, another is from Ministry of the Environment (MOE), project financial support and JCM credit issue.

New System/Installation:

The refrigeration system installed in Indonesia employs "split cycle" refrigeration circuit as same as installed in Japan. Split cycle is a variation of refrigeration cycle using 2-stage compressor. The split refrigerant from the condenser outlet cools down the main stream refrigerant then returns to the 2nd stage compression. In short, it slightly increases compressor input and it increases cooling capacity at the same compressor rotation speed. It enhances the cooling capacity and the efficiency of CO₂ refrigeration systems. The efficiency is better with commercial refrigeration evaporating temperature range compared to HFC-404A refrigeration systems. (16% better in refrigeration and 25% better in freezing, estimated at Japanese climate condition).

The energy saving really depends on the outdoor temperature. High outdoor temperature gives less energy saving. MIDI estimation still gives approx. 20% energy saving compared to HCFC-22 considering the climate conditions in Jakarta, including the advantage of inverter drive of CO₂ system.

In Indonesia, the refrigeration systems installed in convenience stores are changing. There were only several ice-cream and drink showcases but the display area of refrigerated items are increasing. So, energy conservation is one of the most important issues for the convenience stores today.

These conventional showcases are self-contained. The heat pumped from inside the showcases is rejected to the sales floor space. According to the increment of refrigerated showcase, the system configuration has to be changed from self-contained to remote type.

If they install remote type refrigeration systems like commonly used in Japan, the energy consumption and the global warming impact from refrigerant leakage will be a concern because the power consumption is higher and the refrigerant charge amount is larger. Each self-contained showcase is equipped with several hundred watts output compressor and contains several hundred grams of refrigerant. Typical remote type refrigeration system used for convenience stores has 5-6 kW output compressors and the refrigerant charge is around 30 kg.

MIDI had evaluated NH₃ refrigeration systems, field tested at actual stores as New Energy and Industrial Technology Development Organization (NEDO) funded project in FY 2010. Considering global warming impact, installing and safety, MIDI decided CO₂ is suitable for convenience stores.

MIDI have set the CO₂ refrigeration system as standard system for new stores since Sep. 2014 in Japan. MIDI will have installed CO₂ refrigeration systems at 912 stores by the end of Aug. 2015. Before that, MIDI evaluated the feasibility of CO₂ system step by step:

- Pilot store showed energy saving more than expected, FY 2010

• METI funded 50 stores installation project in FY 2011 resulted with:

1. Training for installers and maintenance engineers
2. Study on laws and technical standards in Europe
3. Safety and durability evaluation of installation

MIDI have carried out METI funded projects every year from 2012 for spreading CO₂ refrigeration system.

Twelve stores of this project were financially supported by MOE for energy saving equipment installation as Joint Crediting Mechanism (JCM) project in FY 2013. The financial support is for the total equipment and installation cost. The amount was 1/2 of the cost. In return, Lawson shall give Japanese government 1/2 of CO₂ emission reduction credit issued. 1 store installation was done as part of METI JCM Feasibility Study Project in 2013.

In general, CO₂ refrigeration system performs less at high outdoor temperature. It was said there was a border according to average outdoor temperature and CO₂ refrigeration system is less efficient in tropical and sub-tropical climate, as shown in Fig. 3.

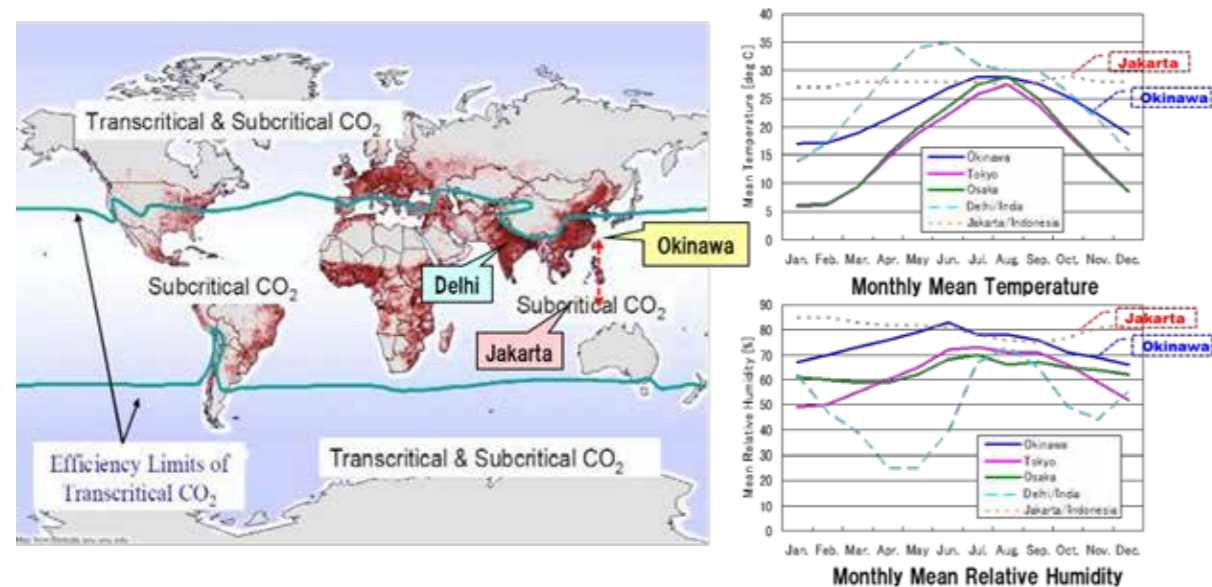

Fig. 3 Map of CO₂ Refrigeration System Performance and Temperature Chart

But previous research showed CO₂ refrigeration systems reduced electricity consumption by 20% in Okinawa in 2012. (Equipment replaced at existing store, Comparison with HFC-404A system) So, it was decided to field test CO₂ system in Indonesia.

Cost issue is the barrier to be removed. The equipment cost and the installation cost are higher compared to HFC refrigeration system even in Japan. The cost gap is larger in Indonesia or other developing countries.

Some subsidies or financial support are necessary for CO₂ refrigeration system spreading in short term, but public relations would be more important that showing the importance of refrigerant leakage control for global warming prevention in long term.

Configuration of CO₂ refrigeration system:

1. 1 of Outdoor unit for Refrigeration, 10hp output compressor
2. 3 of 6 feet width open showcase
3. 1 of 6 door walk-in refrigerator
4. 1 of Outdoor unit for freezing, 2hp output compressor
5. 1 of 2 door reach-in freezer

Operating conditions:

1. Cold room temperature (Refrigeration): 5 deg. C ± 2K
2. Cold room temperature (Freezing): -20 deg. C ± 2K
3. Room temperature (A/C setting): 26 deg. C ± 2K

All the equipment and parts of CO₂ refrigeration and LED lighting was exported from Japan for this project because they are commercially available only in Japan. For the maintenance, a partner company PT. SIGMA BIMED provides 24/7 service for MIDI, storing service parts including backup outdoor units, showcases and lighting parts. A/C equipment is supplied in Indonesia.

CO₂ refrigerant is non-flammable and non-toxic. Only high concentration CO₂ affects human body, so a CO₂ detector is placed inside space of walk-in refrigerator and flash light alarm notifies in case of refrigerant

leakage. CO₂ concentration in sales floor space can't reach hazardous level with CO₂ refrigerant charge amount. Assuming that the air volume is 750m³ and the refrigerant charge is 15kg, the CO₂ concentration is approx. 13,000ppm, it's lower than the safety limit of 40,000.

Performance:

The CO₂ refrigeration systems installed in Lawson stores have been supplied by Panasonic. Lawson and Panasonic have worked together from the R&D stage of CO₂ refrigeration system, it has contributed much on system development, field testing, establishment of installation and engineer training and so on.

The supplier of commercially available CO₂ refrigeration system is very limited in Japan today, but MIDI are expecting more manufacturer come into CO₂ refrigeration system market and compete together for the innovation, quality and cost reduction. That is necessary to spread CO₂ refrigeration system.

The measured power consumption shows the energy savings from CO₂ refrigeration, A/C and LED lighting are 15-20% more than expected as shown in Fig. 4. 3 stores (1 by METI, 2 by MOE) of the project opened early 2014 have been operated for more than 1 year. These data have been stored through a remote monitoring system from the opening.

The knowledge of energy conservation on store operation will be obtained from the analysis of 13 stores data. We would continuously share it with MIDI for energy saving.

Figure 4 shows the energy saving of CO₂ refrigeration systems. The power consumption data were taken at three stores in Jakarta from 1 April 2014 to 31 March 2015. Compared with the power consumption estimated for the same capacity HCFC-22 refrigeration system, the three store's averaged electricity saving is 17,624 kWh/Year and it corresponds to 12.9 ton-CO₂/Year (Assuming that CO₂ emission factor in Jakarta is 0.73 Kg-CO₂/KWH) per store.

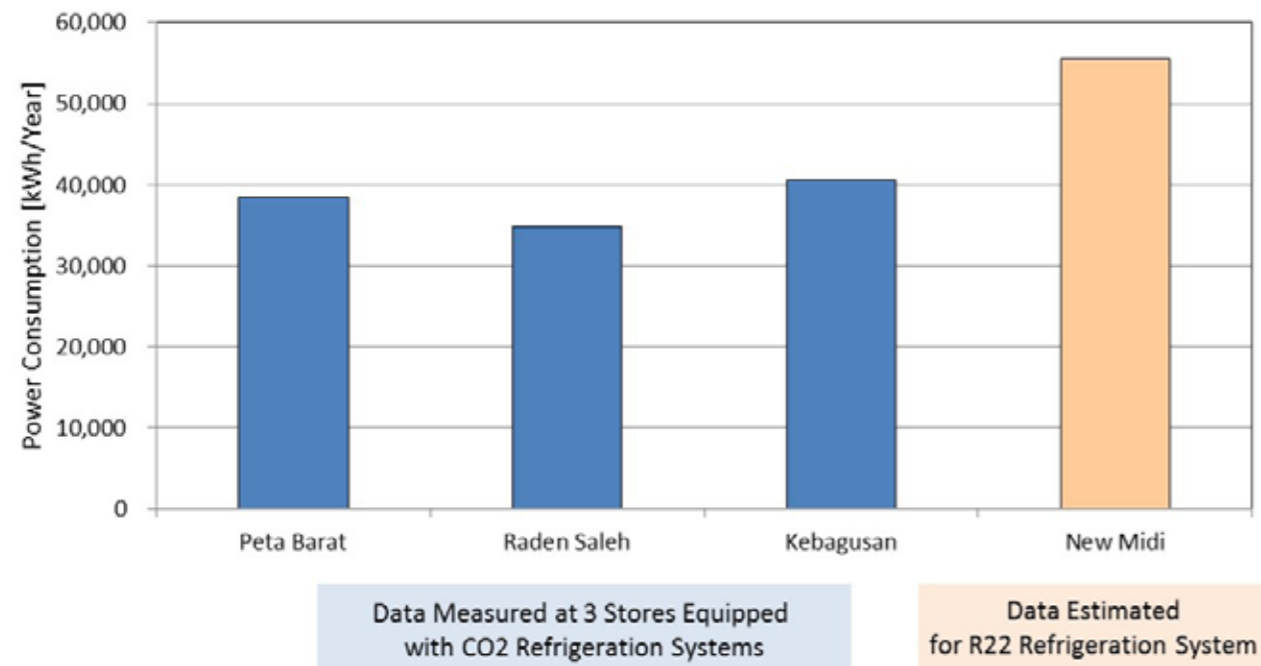

Fig. 4 Annual Power Consumption of Refrigeration Systems (Outdoor Unit Only)

Cost and Economic Considerations:

Cost issue is the barrier to be removed. The initial cost of CO₂ refrigeration system including installation is approx. 1.5 times as much as conventional HFC system (HFC-404A) even in Japan. The cost gap is larger in Indonesia or other developing countries. Some subsidies or financial support are necessary for CO₂ refrigeration system spreading in short term, but public relations would be more important that showing the importance of refrigerant leakage control for global warming prevention.

Disclaimer:

The information presented here is provided by Lawson. The accuracy of the content and figures is the responsibility of the company and these have not been verified by the CCAC or UNEP.

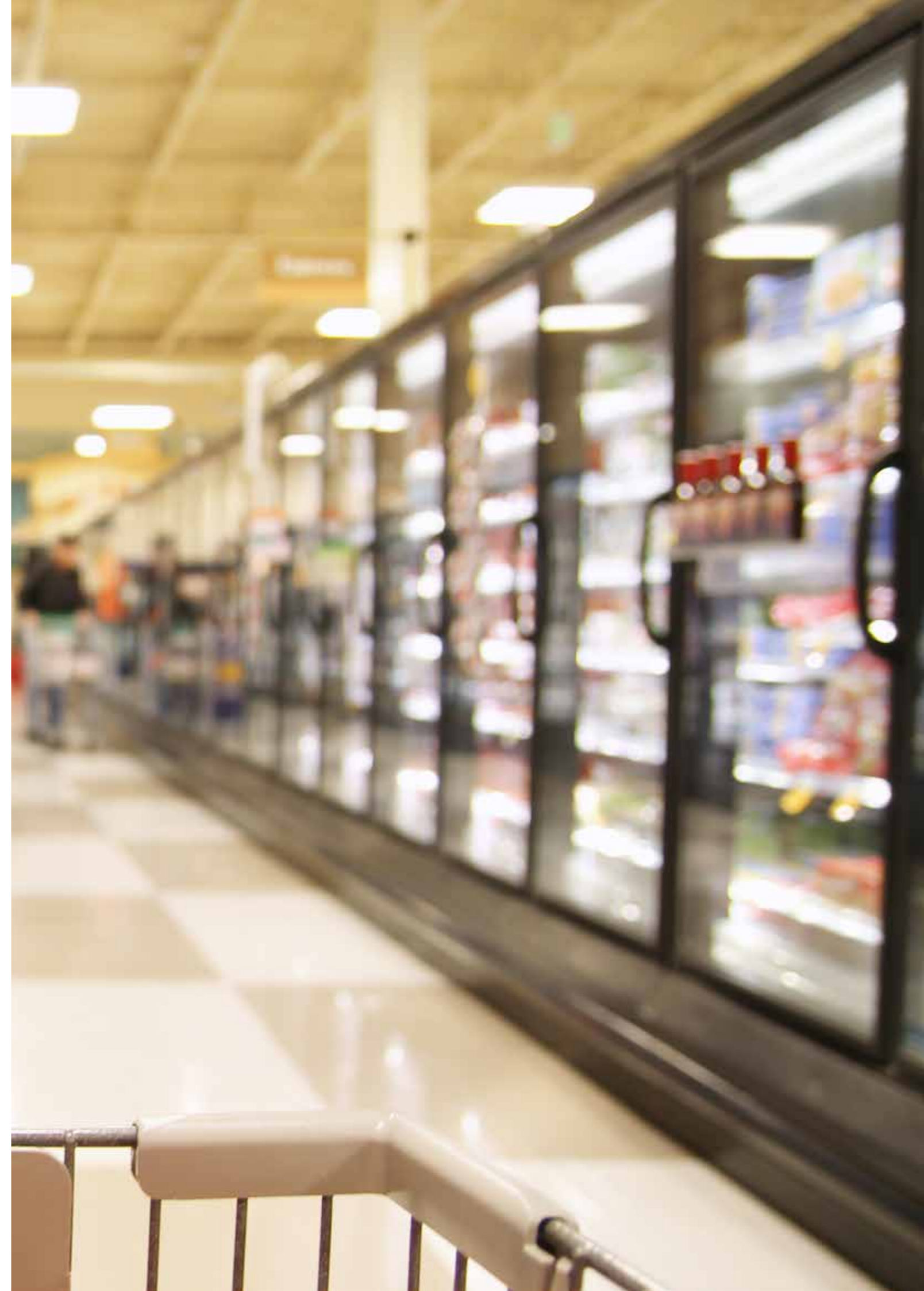

CASE STUDY-5

Lidl, Germany

Name of the Store/facility:

Lidl, Germany

Location:

Heinrieter Str. 3, 74074 Heilbronn

Contact information:

Name: Christoph Kraus
 Email: christoph.kraus@lidl.de
 Designation: Managing Director

Type of Facility:

Food market store, Area: 1634m²
 Refrigeration System type: Centralised system

Refrigerant Used:

Propane (C₃H₈) is a colourless gas which is used as a refrigerant with the identifier R290. As a non-halogenated carbon Hybrid it offers very low Ozone Depletion Potentials (ODP) and Global Warming Potentials (GWP) and is classified as a natural refrigerant. Propane has a GWP of 3.

Project Background:

To create a sustainable building a holistic approach is necessary. Not only do all forms of energy use have to be checked/reviewed, but also the interaction of heating and cooling generators have to be analysed in detail. With the new branch generation LIDL sets standards for energy efficiency and sustainability. All suitable new LIDL-branches in Germany are built according to this forward-looking concept. Fig. 1 shows a photo of the LIDL Food Market.



Fig. 1 Photo of Alfamidi Store

Thereby LIDL applied state-of-the-art energy-design methodologies and tools together with the Engineering experts of Drees & Sommer.

Based on measured data from various LIDL-Pilot-Branches a number of meaningful single measures have been combined to a holistic energy concept using computational models such as thermal building- and services- simulations as well as computational air flow dynamics- (CFD-) and lighting simulations.

Different from recent techniques with decentralised “plug-in” compression chillers using hydrofluorocarbon (HFC, R-404A), the centrepiece of the new energy concept is a centralised “integral plant”, co-designed by LIDL and Drees & Sommer. This plant is an electrically driven chiller plant with an integrated heat pump, designed especially for supermarkets as a compact stand-alone unit for outside installation. The unit on the one hand provides the cooling energy required for the cooling of goods at a temperature level above 0 °C. The surplus heat energy resulting from this process, which used to be given to the outside air through the year, can now be re-used for the supply of heat during the winter months (concrete core activation and ventilation system).

New System/Installation:

In order to manage the simultaneous energy demands and to maximise the energy savings, a combined building control unit for cold production, heat, ventilation and lighting has become a central component of the integral plant. Fig. 2 shows a photo of Integral Chiller plant installed outside.



Fig. 2 Photo of Outdoor Integral Chiller Plant Installation

The plant is fully operated with natural refrigerants. A separate refrigeration circuit with a natural propane refrigerant is located inside the integral plant. With this circuit the “standard cooling” for goods above 0°C and the heat for the whole branch is being produced.

Compared to the widely-used natural refrigerant CO₂ (R-744) Propane has a comparable ODP and only marginal higher GWP, but has much better thermodynamic characteristics. As a result, propane needs lower pressures in the refrigerant circuit, which significantly reduces the electrical energy consumption of the plant’s components. In terms of energy balance Propane therefore is the more environment-friendly alternative.

Propane was so far used in systems with very low filling capacities (<150g) such as plug-in deep-freezers. In this field Propane has been established for a long time because of its energetic advantages and economic aspects. For years LIDL therefore exclusively used deep freezers with the natural refrigerant Propane, which are state-of-the-art in terms of energy efficiency, and avoid harmful effects on the world’s climate. Fig. 3 and

4 shows a sectional view and schematic diagram of integral plant concept used in Lidl.

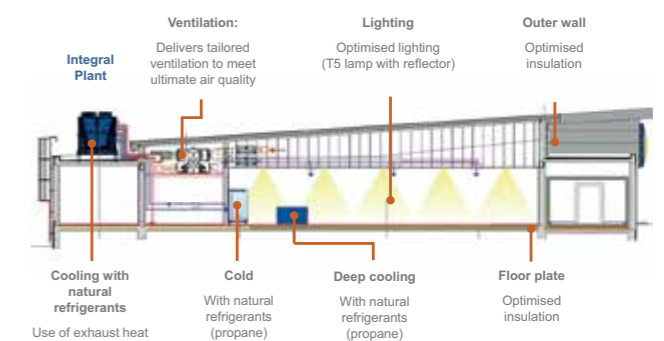

Fig. 3 Sectional view of Integral Plant Concept

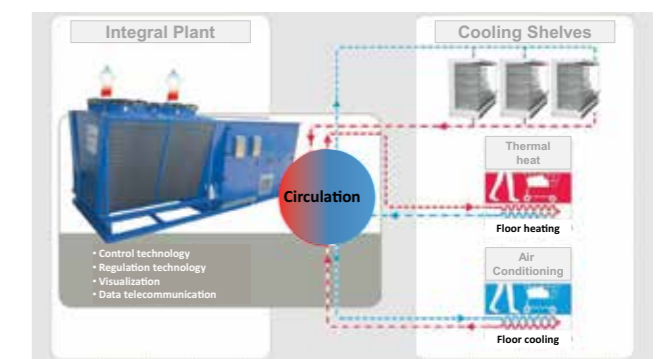

Fig. 4 Schematic of Integral Plant concept

With comprehensive emergency systems and the outdoor-use of the integral plant these remarkable advantages could be transferred to a larger plant.

Inside the LIDL markets an environment-friendly brine solution (“Temper”) based on organic salts is being used exclusively as refrigerant in the secondary system, in order to fulfil the requirements of environmental friendliness and energy efficiency. Temper is neither inflammable nor toxic and is therefore an ideal refrigerant due to its high heat capacity and good cold flow characteristics.

The Temper-circuit transports the cooling energy to the multi-deck cooling cabinets. There the salt solution provides it cold to the food and heats up at the same time. After that, the warm solution flows back into the integral plant, where the heat is transferred into the Propane circuit. The Propane is further heated using a compressor. The resulting heat is used in winter via a water circuit for the heat energy supply in the market, as described above.

Performance:

Since all heat consumer appliances consequently have been designed to low system temperatures, the integral plant can operate exceedingly efficiently and cover 100% of the heating energy demand from the waste heat of the cooling process. For peak load situations, where the heating energy demand would exceed the waste heat level from the chillers, the chiller compressor can operate as an additional heat pump system. With the exception of the electrical power supply no fossil fuels such as oil or gas is required in any branches.

During summer, 100% of the waste heat from the chillers still can be expelled to the outside air. At the same time, the integral plant can provide cooling energy, to supply the concrete core activation (i.e. the floor heating / cooling system) for the branch's cooling. In addition to the conventional heating system a separate cooling system therefore can also be omitted.

Compared to a conventional food market the various measures result in savings of about 16 MWh of electricity – the annual consumption of four single family homes. The heating energy demand is reduced by about 100 MWh – the annual consumption of eight single family homes. The branch furthermore has an overall CO₂-emission reduced by 55 tons per year – this represents the average annual emissions of 30 cars.

With the new generation of branches LIDL created a food market, which is trend setting in many ways. 100 percent less heating energy demand, 30 percent less CO₂-emissions a 10 percent less electricity consumption compared to a conventional food market.

In October 2009 this sustainable energy concept of the new LIDL branches has been awarded with a special Energy management-Award for extraordinary technical achievements. The concept which has been rolled out as a new standard and has furthermore has been labelled with a silver-award of the German Council for sustainable buildings (DGNB).

With the new branch concept LIDL also has become a member of the European Green Building-Partner-Programme, which has been initiated by the European Commission in order to support the reduction of energy consumption and CO₂-emissions of non-residential buildings.

Cost and Economic Considerations:

It has been found that, Lidl is able to save an amount of approx. 7T€/annum of energy costs. That provides a Return on Investment (ROI) of approx. 5 years.

Disclaimer:

The information presented here is provided by "Lidl". The accuracy of the content and figures is the responsibility of the company and these have not been verified by the CCAC or UNEP.



CASE STUDY-6

Ahold, Netherlands

Name of the Store/facility:

Ahold, Netherlands

Location:

Various

Contact information:

Name: Peter W. Vlaskamp

Email: peter@vlaskamp.biz

Designation: Refrigeration Consultancy for Ahold group

Type of Facility:

Supermarkets;

Refrigeration System type: Centralised system

Technology Transition:

Retrofit from HFC-507A centralised direct expansion refrigeration systems to Opteon™ XP40 (R-449A). HFC-507A has a Global Warming Potential (GWP) of 3985 and R-449A has a GWP of 1397.

Refrigerant Used:

The new refrigerant used is Opteon™ XP40 (R-449A) which is part of the new lower GWP (Global Warming Potential) refrigerant portfolio from Chemours and is suitable as an alternative to HFC-404A/HFC-507A for the retrofit of commercial and industrial medium and low temperature refrigeration systems. With a GWP of 1397 (IPCC AR4, Intergovernmental Panel on Climate Change, 4th Assessment Report), its global warming potential is 65 percent lower than HFC-507A (IPCC AR4 GWP of 3985). The formula of Opteon™ XP40 is R-32/125/1234yf/134a at 24.3/24.7/25.3/25.7 wt%.

Project Background:

As part of its program to cut its carbon dioxide (CO₂) emissions, Ahold, a Dutch retailer, converted the refrigeration systems in some 200 of its supermarkets to new Opteon™ XP40 (R-449A) refrigerant from Chemours. This decision was the outcome of practical trials which the company carried out in close cooperation with Chemours Fluoro-products and the Dutch consultants P.W. Vlaskamp B.V. Refrigerants Consultancy, Sleenwijk. In comparison with HFC-404A/HFC-507A, Opteon™ XP40 from Chemours has around

65 percent lower global warming potential and is also significantly more energy efficient. Moreover, its elevated energy efficiency means it can help in bringing about a significant reduction in the overall CO₂ emissions arising from refrigeration system operation.

Ahold has the target of cutting its CO₂ emissions per square meter of its sales floor by 20 percent relative to 2008 levels by 2020. This involved reducing the overall greenhouse gas emissions arising from leaks and energy consumption of their Copeland medium and low temperature compressors, which had originally been operated with HFC-507A. The company accordingly tested various alternative refrigerants with reduced global warming potential.

Over the course of this project, three medium-sized centralized direct expansion (DX) supermarkets in Amsterdam and Marum, Holland were converted to Opteon™ XP40, one from R-407F and two from HFC-507A. XP40 was specifically chosen due to its GWP properties lower than HFC-404A and 507A, lower discharge temperature compared to R-407F and the potential for energy efficiency increases. With non-flammability and low toxicity, Opteon™ XP40 was also chosen as the replacement refrigerant due to the low risk it poses to both employees and customers. Fig. 1 shows a picture of Ahold supermarket in Netherlands.



Fig. 1 Ahold Supermarket, Netherlands

New System/Installation:

The conversion was carried out in November 2013, by Retail Technics B.V., Nijkerk, The Netherlands. The work took three to four hours in each case and was carried-out outside opening hours. Once the original refrigerant charge had been removed, the filter dryer was firstly replaced, as is usual during servicing. The system was then evacuated, subjected to leak testing and filled with Opteon™ XP40. Since the company uses electronic expansion valves and the Danfoss ADAP-KOOL® System, the system set up was very easy for Opteon™ XP40 with new coefficients entered via laptop. No further components had to be replaced nor was an oil change required. Measurements before and after the retrofit revealed that this refrigerant has an 8% higher energy efficiency than the previously used HFC-407F and HFC-507A. Fig. 2 shows a picture of the system installation at Ahold supermarket.

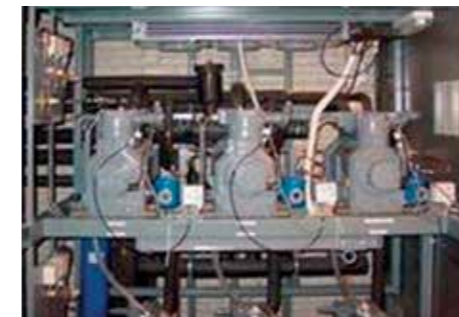

Fig. 2 Ahold Supermarket, Netherlands

The technical manager from Ahold said: "The conversion to Opteon™ XP40 was completely straightforward and unproblematic in every case. Calculations carried out together with Chemours and Vlaskamp have shown that the capital expenditure will be paid back within an acceptable time due to the refrigeration systems' significantly lower energy consumption. Management has therefore decided to convert some 200 systems which are currently operated with HFC-507A to the new refrigerant from Chemours. Work started in September 2014 and was completed less than a year later in June of 2015."

Performance:

The consultant has calculated that full conversion of about 200 stores to Opteon™ XP40 will cut total direct greenhouse gas emissions by 10,360 tonnes of CO₂ per year. Ahold had decided to switch to XP40 as a result of the new European F-Gas Regulation (EU) No. 517/2014 which entered into force on 1 January 2015 and specified that the number of tons of CO₂ equivalents available on the market will be gradually reduced over a 15 year period. In addition, from 1 January 2020, servicing systems using HFCs with a GWP value of 2500 or more will be prohibited for the majority of commercial applications. Changing HFC-404A/HFC-507A refrigeration systems over to Opteon™ XP40 will ensure that these installed base systems will continue to comply with the requirements of this regulation for the remainder of their service life. This discipline is for the company an extra step next to the future new installations which will be built according to the Consumer Goods Forum (CGF) resolution, which aims to begin phasing-out HFC refrigerants in new commercial systems as of 2015. Fig. 3 and 4 shows the Energy consumption versus ambient temperature chart for medium and low temperature systems respectively.

Opteon™ refrigerants, including XP40, are now commercially available within the EU and the United States, and are being used to transition a variety of applications across numerous industries to lower-GWP refrigerants. Chemours has made significant investments to bring Opteon™ products with no ozone depletion and lower global warming potential to the market, and plans to bring additional capacity online to serve a wide range of applications.

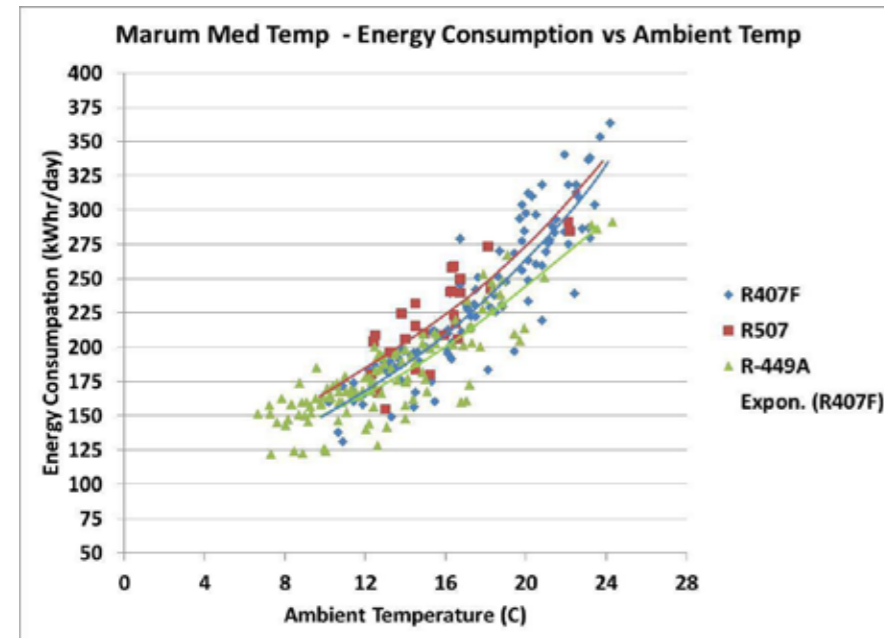

Fig. 3 Energy consumption Vs Ambient Temperature for Medium Temperature System for Retail store in Marum/ NL, where the MT system has been retrofitted from HFC-507A to Opteon™XP40.

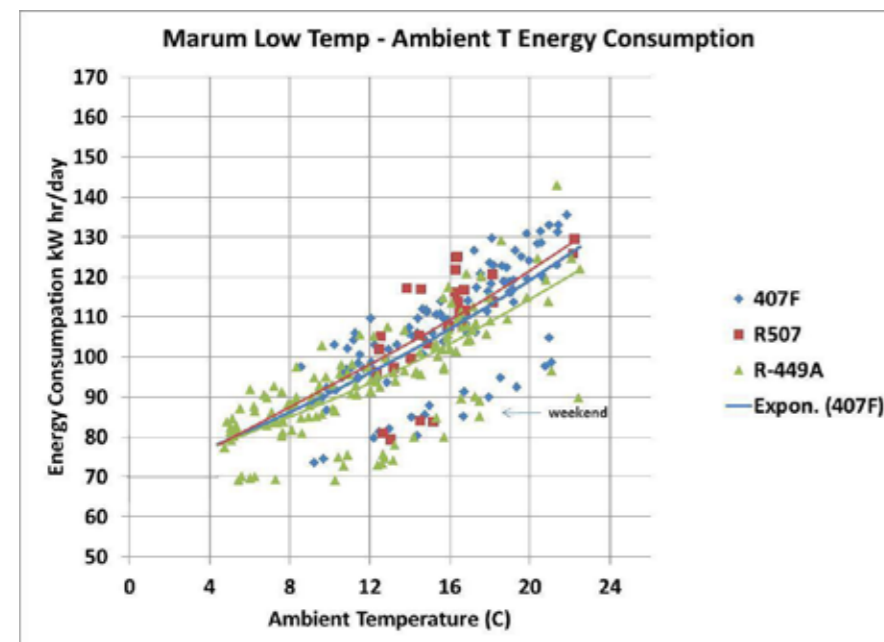

Fig. 4 Energy consumption Vs Ambient Temperature for Low Temperature System for Retail store in Marum/ NL, where the LT-system has been retrofitted from R507A to Opteon™XP40.

Cost and Economic Considerations:

Following the retrofits, Ahold experienced an average energy consumption reduction of 8% for their combined medium and low temperature systems. Due to the lower energy consumption, the retrofit investment costs are calculated to be paid back in less than five years, assuming typical operating conditions in the Netherlands.

Disclaimer:

The information presented here is provided by Chemours/Ahold. The accuracy of the content and figures is the responsibility of the company and these have not been verified by the CCAC or UNEP.

CASE STUDY-7

CarrefourSA Express Kurtköy Commercial Refrigeration, Turkey

Name of the Store/facility:

CarrefourSA Express Kurtköy

Location:

Kurtköy, Turkey

Contact information:

Jean-Michel Fleury, Jean-Michel_Fleury@carrefour.com

Type of Facility:

Hypermarket, Store Area =765 m²,
Food & Department Store.

Technology Transition:

Transition from High-GWP refrigerant R-404A to CO₂.

Project Background:

As part the Carrefour Group's effort to mitigate climate change by reducing HFC refrigerant charge and refrigerant leakage, the Group has set a goal to phase out HCFCs in new refrigeration equipment by 2015. Currently Carrefour is progressively rolling out full CO₂ systems, having installed its first CO₂ transcritical refrigeration system in Istanbul, Turkey, at the Kurtköy-Millennium Carrefour Express. Fig. 1 shows photo of the store in Kurtköy, which has a sales area of 765 m². The retrofitted refrigeration system in the Turkish Kurtköy store entered into operation on 9 May 2012, and is one of four sites operated by the retailer that use 100% natural refrigerants.

In more than 30 stores across Europe, Carrefour was already using a hybrid solution such as a cascade system, which combines synthetic refrigerants and CO₂, but the change-over to an installation that operates solely with CO₂ marked a clear shift to natural refrigerants. Carrefour plans to continue to set up new stores across Europe using natural refrigerants.

"Carrefour states that the market penetration of CO₂ commercial refrigeration could be further accelerated if qualified contractors were more widely available to cater for the needs of the booming CO₂ refrigeration market. This is relevant for countries outside the European market and more particularly in Asia and Latin America." — Jean-Michel Fleury, Director of Assets Carrefour Group.



Fig. 1 The CarrefourSA Express Kurtköy, Turkey

New System/Installation:

Food refrigeration accounts for two-thirds of the Carrefour Group's greenhouse gas emissions. The emissions arise from refrigerant leaks, as well as from electricity consumed by refrigeration equipment. To reduce these emissions, Carrefour Turkey is piloting a highly innovative solution - using the natural fluid CO₂ for both refrigerators and freezers at the Kurtköy store. The technology used in Turkey is new to that part of the world, and is only the fourth time it has been used by the Carrefour Group. CO₂ is being used as the alternative to the original HFC refrigerant R-404A. R-404A, with a GWP of 3,922, is an HFC refrigerant, a colorless, odourless mixture which is used as a replacement for R-22, a refrigerant which is being phased out under the Montreal Protocol.

The new Kurtköy's CO₂ installation has the following dimensions:

There are 13 showcases for positive temperature products, and two for negative temperature products, which equates to 33 meters of refrigeration displays. Compressor racks are used to provide cooling for these showcases at negative and positive temperatures. The capacity of the positive rack compressors is 40 kW, and negative rack compressors 4 kW.

The technical specifications for the compressor racks include:

The compressor rack for medium temperature applications is composed of four Bitzer compressors with a total refrigeration capacity of 67.44 kW, and

a coefficient of performance (COP) of 1.12. This COP is during the summer when the gas cooler outlet temperature is 45° C, while in winter time the COP is 6.99. The compressor rack for the low temperature side is composed of one Bitzer compressor with a total refrigeration capacity of 4.80 kW, with a COP of 4.58. Fig. 2 shows a photo of the five-compressor rack.

The design using CO₂ is similar to a typical transcritical system. Since the pressure level is higher than 70 bar the piping design requires the use of steel pipes throughout. A transcritical CO₂ system operates in transcritical mode whenever the refrigerant is above



Fig. 2 The CO₂ compressor rack

31° C. The condenser becomes a gas cooler at temperatures above 31° C and the CO₂ leaving the evaporator is supercritical, a state where vapour cannot condense and one cannot distinguish liquid from vapour.

Where the pressure level is less than 45 bar, the design is like that for any traditional refrigerant.

The system also has a solution for decreasing the ambient temperature by using the ChillBooster™ adiabatic air cooling system. The ChillBooster™ is manufactured by CREA (Italy).

Fig. 3 is a schematic for the ChillBooster™ system used for high ambient conditions. The system works on cooling the air to a lower temperature going over the coils by evaporative cooling. ChillBooster™ atomises water into very fine droplets that evaporate

spontaneously, cooling the air. The coil is thus cooled by a flow of colder air and droplets of water, allowing more favourable operating conditions and thus increasing the cooling capacity of the system.

ChillBooster™ can be used as an extra cooling step only on high temperature days. The droplets of water are evaporated by absorbing heat from the air and, as a consequence, it can decrease the air inlet temperature by up to 15° C to help the system run in optimal conditions (see Fig. 3). This system works best in dry climates, but it is still possible to give reasonable results in higher humidity areas. The system works everywhere except in areas that have both a high temperature and high moisture content simultaneously.

Schematic of the ChillBooster™ System



Fig. 3 Schematic for the ChillBooster™ showing how the high ambient temperature air is cooled by water droplets before passing over the coil.

Performance:

The system has been operating in Kurtköy, Turkey where the annual average temperature varies from 0.5° C to 25.7° C. In only 12 months of operation, the technology has significantly reduced the environmental impact of the store. The CO₂ used in the refrigeration system is around 3,922 times less potent in terms of global warming potential than the refrigerant (R-404A) previously used at Kurtköy.

The quantity of CO₂ needed for the refrigeration units is approximately one-third less than the refrigerant charge required by a conventional system.

The performance of the CO₂ system is compared to similar cooling capacity systems operated in roughly similar climatic conditions using R-404A.

The quality of the pipe fittings has been improved and as a result, refrigerant leaks are expected to be reduced by 75%.

The CO₂ solution improves the energy efficiency of the refrigeration units by around 15%, which equally limits CO₂ emissions resulting from electricity consumption.

Advantages of this CO₂ System

- High-GWP refrigerants (which can be a direct contributor to global warming when leaked to the atmosphere) are reduced.
- Total elimination of HFCs from the system.
- High Volumetric capacity - The system can absorb

much more heat than an HFC-based system, resulting in reduced compressor and pipe size for the same cooling effect.

- Low HFC refrigerant charge for subcritical systems
- Lower than HFC Refrigerant Costs - CO₂ costs are currently 90% less expensive than traditional refrigerants (US\$2.2/kg versus US\$24.2/kg for R-404A).
- Reduced Carbon Footprint - CO₂ has a GWP of 1 vs. HFC which has a GWP of 3,922 for R-404A.
- Reduced Carbon Emissions - Because the refrigerant is confined to a machine room, there are fewer braze joints and a significant reduction in potential for leaks in the system.

Disadvantages of transcritical CO₂ System

- Higher investment cost (the components capable of being operated safely in such high pressure applications can be more expensive).
- The COP of the system is reduced when operated in higher ambient conditions.
- CO₂ is heavier than air - importance of good ventilation in case of leakages
- Limited local expertise for service and maintenance in Istanbul. The flash gas leakage causes formation of dry ice on the system.
- Compressor range is very limited (but increasing).
- Difficult to obtain components at present.

Some of these disadvantages can be overcome with time when systems become more prevalent and through improved training of technicians.

Cost and Economic Considerations:

In addition to its excellent technical performance, the CO₂ transcritical installation also offers very significant economic benefits. The Kurtköy hypermarket should not only reduce its overall annual energy bills by 7%, but it should also be able to reduce the amount spent on refrigerants, which is crucially important given that the price of synthetic gas is increasing.

Disclaimer

The information presented here is provided by Carrefour. The accuracy of the content and figures is the responsibility of the company and these have not been verified by the CCAC or UNEP.

CASE STUDY-8

Sobeys Commercial Refrigeration, Canada

Name of the Store/facility:

Sobeys, IGA Cookshire

Location:

35 rue Principale Est, Cookshire, Québec J0B1M0, Canada

Contact information:Rod Peterson, National Procurement Manager,
Rod.Peterson@sobeys.comDavid Smith, VP of Sustainability,
David.Smith@sobeys.com**Type of Facility:**Supermarket, Store Area = 1,950 m², Grocery and Food Retailer, Store has LEED certification.**Refrigerant Used:**CO₂ transcritical refrigerant systems**Project Background:**

Sobeys owns or franchises more than 1,300 stores all across Canada under different retail banners. In the province of Quebec, Sobeys operates under the IGA brand. In February 2010, the new IGA Cookshire store opened. The new supermarket is a state-of-the-art one, having been built to LEED (Leadership in Energy and Environmental Design) specification with environmental considerations throughout the building. Fig. 1 shows a photo of the Sobeys store. Amongst the environmental features of this 1,950 m² supermarket are improved air quality, such as low VOC (Volatile Organic Compound) finishes and natural ventilation. Moreover, the transcritical CO₂ refrigeration system reduced a large amount of greenhouse gas emissions relative to traditional systems used in other Sobeys stores.

The Carnot Refrigeration Company was retained by Sobeys in order to develop an alternative to the conventional refrigeration systems available on the market, which were less efficient, and incurred high maintenance costs. The goal was to provide a sustainable and reliable solution that would have lower initial (equipment and installation) and operating



Fig. 1 Photo of the Sobeys, IGA Cookshire in Quebec, Canada

(energy, maintenance, gas replacement, insurance) costs. After many internal discussions, the management concluded that there were substantial benefits to eliminating HCFCs completely and focusing on a full transcritical CO₂ refrigeration system. Furthermore, in 2010, Sobeys endorsed the Consumer Goods Forum's natural refrigeration initiative (<http://www.theconsumergoodsforum.com/sustainability.aspx>), which encourages members to phase out HFC refrigerants in all new builds from 2015.

Sobeys' Quebec division piloted the approach to natural refrigerant systems. It had already installed low GWP transcritical CO₂ systems when in 2009 a national initiative was undertaken to review alternatives to traditional HCFC refrigerant systems, with a particular focus on various CO₂ systems. Several CO₂ options were considered, including the following:

- Secondary Loop Medium Temp (MT) Glycol and Low Temp (LT) CO₂ liquid
- Secondary Loop MT Glycol and LT Cascade CO₂
- Secondary Loop MT CO₂ liquid and LT CO₂
- Secondary Loop MT CO₂ liquid and LT Cascade CO₂
- Transcritical CO₂ DX.

"Sobeys' transcritical refrigeration system design is the solution for our climate here. It is meeting our entire vision." — Simon Bérubé, *senior director of engineering and commercial development, Sobeys Quebec.*

New System/Installation:

The transcritical CO₂ refrigerant system, which has become the new national standard for refrigerant systems at Sobeys, is a low GWP (Global Warming Potential) transcritical CO₂ system. It will be included in all new builds and will be considered for retrofits where feasible based on the store size and scope of the retrofit. Within these systems CO₂ levels are monitored for leakage; however, because CO₂ is a natural gas, these systems do not pose the same risk to the environment (due to leakage) as traditional HFC systems.

The average Sobeys supermarket refrigeration system contains 1,130-1,360 kg of HCFC refrigerant R-22. HCFC refrigerants have an ODP above zero and also significant GWPs of 1,810-4,657 and are therefore responsible for a significant portion of a typical supermarket's direct carbon footprint due to leakages. The common HFC replacement option for R-22 is R-507 or R-404A. Refrigerant R-507 has a GWP of 3,985, where a 1 kg leak of R-507 is equivalent to 3,985 kg of CO₂ emissions. Average rates of leakage of these refrigerants are between 10% and 30% per store each year, and almost 30% of Sobeys' stores' aggregate carbon footprint.

The transcritical CO₂ refrigerant system shown in Fig. 2 uses only CO₂, which has a GWP defined to be 1, as compared to the higher GWP of R-507. The CO₂ systems are energy efficient in comparison with traditional refrigeration systems, and especially with the combination of heat reclaim introduced with them, provide a net reduction in store energy consumption. The intensive reclaiming of waste heat from the refrigeration units can be used to cover almost all the heating needs of the supermarket. A pre-heating water loop is also installed in the supermarket to preheat hot water used within the store.

Fig. 3 is a schematic diagram and process explanation of the Carnot Refrigeration Transcritical CO₂ system used at Sobeys.



Fig. 2 Photos of the transcritical CO₂ system at Sobeys designed by Carnot Refrigeration.

**Challenges**

One of the initial challenges and concerns when installing these systems was that of contractor training and timely access to new components. It was unclear if contractors would be familiar enough to service and work with these systems. This was a particular concern as Sobeys considered scaling up and extending new builds into stores far from the Quebec location of the CO₂ system manufacturer where direct support from the system manufacturer would be much less readily available than during the Quebec pilot phase. However contractors were found to be increasingly embracing this technology and investing in servicing and installation training as these systems become more common. Another challenge was building the company's plan for the transition to transcritical CO₂ because of the differences in geographical and infrastructural constraints between stores. Furthermore, there are also financial challenges. At this stage, as early adopters, the Sobeys systems are still fairly expensive in capital cost terms compared to future projections, thus the return on investment (ROI) is dependent on the size and nature of the store, whether heat reclaim is already in place, and sometimes whether

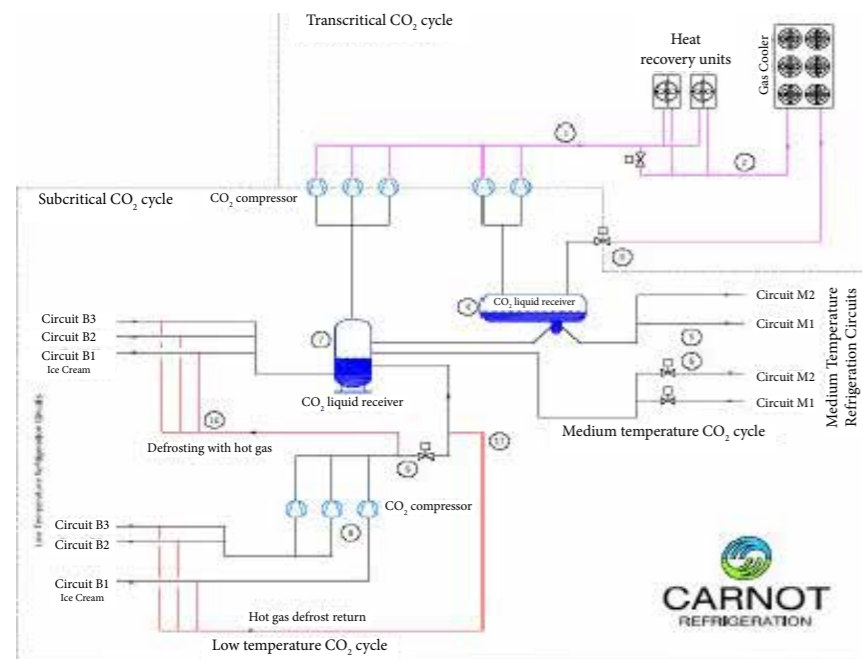

Fig. 3 Diagram explanation of the Carnot Refrigeration Transcritical CO₂ system

government incentives exist. These systems at Sobeys have a 3-4 year average return on investment. However, as mentioned above, the company expects costs to decrease and installation and infrastructural support to become easier as these systems become more prevalent and efficient. This presents the opportunity to reduce the cost curve.

Emerging out of these challenges and the commitment to this system, many lessons have been learned. For example, in order for the company's contractors and suppliers to provide the services needed for a new system, they need to be engaged early in the overall process from designing the system through the procurement and installation stages. They need to also understand the advantage of such a system in order for them to develop expertise on these new refrigeration systems, as it does require investment in training and adds complexity to their businesses. It is also important to look ahead, when conducting a business case study on return on investment (ROI), because what may not be feasible today may very well be feasible in the near future as regulations and industry initiatives drive adoption of these systems. Cost forecasts for

refrigerant re-charges and energy savings are important considerations in such cases.

Performance:

Sobeys has made a commitment to alternative CO₂ refrigeration technology and is very pleased with the results. The installation of these transcritical CO₂ refrigerant systems with heat reclamation has not only made financial sense, but clearly makes environmental sense and is in line with Sobeys' commitment to reducing its CO₂ footprint and impact. The approach taken to come up with performance indicators was applied equally to all stores of identical nature. Therefore, the results will be reported per store. The following are the calculated reductions in comparison to a traditional HCFC refrigerant system:

- Carbon dioxide emissions reduced by 62% = 861,920 kg CO₂-equivalent per year, per store
- Energy consumption reduced per year by 15% -18%
- Natural gas (heating) consumption reduced per year by 75% - 85%

Note that Sobeys experience with the performance of transcritical CO₂ systems is based on all of their stores being located in temperate climates (annual average temperature 0° C to 20° C) in the Northern Hemisphere. Stores located in higher ambient temperature zones would have different design parameters and operating conditions, and therefore these reductions in CO₂ emission and in energy consumption will vary.

Cost and Economic Considerations:

The initial capital costs of a transcritical CO₂ system are more than traditional HCFC DX systems (approximately 11% increase in capital for refrigeration equipment), however operating costs and energy savings will offset the initial capital cost. The simple payback on a transcritical CO₂ system with heat reclaim is less than three years.

Cost savings are a result of lower maintenance (including significantly reduced refrigerant re-charge costs) and energy costs. While it is financially viable to move forward to implement such projects today, Sobeys is proceeding with this technology knowing that the initial capital costs will be rapidly reduced through design, manufacturing and installation efficiencies, and as the Montreal Protocol deadlines for HCFC phase-out approach these systems will become more prevalent and standardised throughout the supply chain.

The following simplified annual financial analysis of a single supermarket assumes that heat reclaim is included as a standard feature, as it helps to drive the reduction in operating costs. Moreover, it is generalised

across Canada, where heat, energy, refrigerant, installation and maintenance costs may vary.

Total incremental capital cost for the refrigeration system increased by 11%.

Total installation costs reduced by 0% to 15%.

Maintenance costs reduced by 50% (as experienced across stores in Sobeys Quebec, this would be the average annual refrigeration maintenance costs of a typical IGA store). A large part of the cost reduction would be replacement refrigerant gas from leaks.

Heating cost reduced by 75% to 85%.

Simple payback within three years.

Fig. 2 and 3 are courtesy of Carnot Refrigeration. Fig. 1 is courtesy of www.voirvert.ca

Disclaimer

The information presented here is provided by Sobeys. The accuracy of the content and figures is the responsibility of the company and these have not been verified by the CCAC or UNEP.

CASE STUDY-9

Verdemar Commercial Refrigeration, Brazil

Name of the Store/facility:

Supermercado Verdemar – Nova Lima Store

Location:

Belo Horizonte, Brazil

Contact information:

Carlos Arruda – marketing@superverdemar.com.br

Type of Facility:

Gourmet supermarket, Store Area = 1,800 m²,
Small chain fine food and wine retailer.

Refrigerant Used:

CO₂ cascade system with HFC (R-134a) refrigerant as the high side fluid. The new installation uses a cascade system composed of a twin primary system using 75 kg of R-134a (GWP=1430), and a secondary system using 100 kg of CO₂

Project Background:

The Supermercado Verdemar – Nova Lima Store was opened in 2010, at Nova Lima, Brazil, 10 kilometers from Belo Horizonte, at an altitude of 1,350 meters above sea level. The building has 1,800 m² of store floor and 500 m² of kitchens and cold chambers. Fig.1 shows a photo of the external view of the store.



Fig. 1 Photo of Supermercado Verdemar - Nova Lima Store

Alexandre Poni, Executive Director of supermarket chain Verdemar highlighted the leading role that company executives must take in driving sustainability to the retail sector, during his presentation in a conference “Sustainability as a competitive advantage” held in São



Fig.2 Photo of the store's refrigerated showcases

Paulo. Towards that vision, Verdemar adopted a CO₂ cascade system after undertaking studies on energy efficiency, environmental impact, installation cost reduction and maintenance cost optimisation.

After two years of research the final project design and installation took 30 days and 60 days, respectively. The main challenges were importing special high technology parts and components and ensuring that the relevant personnel were properly trained to operate the system. Fig. 2 shows a photo of refrigerated cases inside the store.

New System/Installation:

The approach is to use CO₂ as one of the fluids in a cascade system along with an HFC refrigerant (R-134a) as the high temperature fluid. R-134a, is an HFC haloalkane refrigerant with GWP of 1,430. Such systems may have a much lower HFC refrigerant charge, and the global warming potential is reduced compared to a baseline system using only HFC refrigerant.

TECHNICAL DATA:

- Cascade system built inside a large rack that holds most of the working components.
- The Primary dual circuit system is based on R-134a with a load of 136 kg of gas, industrially mounted and piped inside the cooling unit rack in the main rack, using a small volume of gas. This system has zero history of leaks and approximately one-third the amount of GWP as compared to a system using only R-404A or R-507.

- The Secondary system is based on R-744 (CO₂), developed with special high technology parts and components, working on Direct Expansion (DX) or in liquid fluid subsystems.
- The CO₂ subcritical scheme was specially fine-tuned by lowering the condensing temperature of the R-134a primary system to 40° C and raising the evaporation temperature to -8° C, resulting in 71% less energy consumption with a payback period of 19 months. This is achieved by a special patented adiabatic cooling system at the primary condensation circuit allowing a very efficient heat exchange.
- The use of Electronic Expansion Valves were mandatory for better control of the large expansion capacity of CO₂ and to prevent return of liquid to the compressor, as well as keeping stable temperatures at refrigerated points, shorter response time to changes, shorter operation of compressors and lower power consumption.
- Low cost, low power iQ motors (70% energy savings) at the secondary liquid fluid systems, with special larger area evaporators developed by Arneg. The savings are compared to traditional DX HCFC showcases used in the past. It is important to mention that this solution avoids the need for defrosting, hence additional energy savings is achieved.
- High efficiency, progressively activated fans at the condenser, with Electronically Controlled (EC) variable speed DC motors; working on a high-efficiency moist hives adiabatic cooling system, patented by Plotter-Racks Brazilian contractors.
- High-efficiency fans with dual speed ESM⁷ DC motors in evaporation grids, especially at the production sectors, with energy savings of 36% and a payback period of 14 months, and better ergonomic comfort work conditions.
- Frequency regulated pumps, with energy savings of 19% and a payback period of 21 months.
- Frequency regulated Bitzer compressors, with energy savings of 8% compared to conventional compressors

without frequency regulation and a payback period of 23 months.

- Low condensing pressure (30 bar).

This profile installation was then deployed in the two stores opened in 2010 and 2011 and at the main Warehouse in 2012, and has since been adopted as a standard for the chain.

So far, the company operates on CO₂ in three out of its eight stores. There are also two new stores in 2013, and plans are in place to convert the older stores to CO₂.

AMBIENT CONDITIONS:

Maximum expected temperature: 38° C
Wet bulb temperature: 24° C

REFRIGERATION LINES CAPACITY:

Medium temperature (without condensation): 204 kW
Low temperature: 35 kW

MEDIUM TEMPERATURE SYSTEM

Medium temperature chiller with secondary fluid
Primary Fluid: R-134a
Secondary Fluid: Propylene Glycol
Evaporation temperature: -8° C
Maximum condensation temperature: + 40° C
Total unit capacity: 249 kW

LOW TEMPERATURE SYSTEM

Direct Expansion rack for frozen products
Primary fluid: R-134a
Secondary fluid: R-744 (CO₂)
Evaporation temperature: -29° C
Maximum condensation temperature: -4° C
Total unit capacity: 36 kW

Figures 3 and 4 show diagrams for the medium and low temperature systems respectively.

The main lesson learned was that, after personnel training and the construction of a good system with a solid design, the new installation became as easy

Medium temperature system diagram

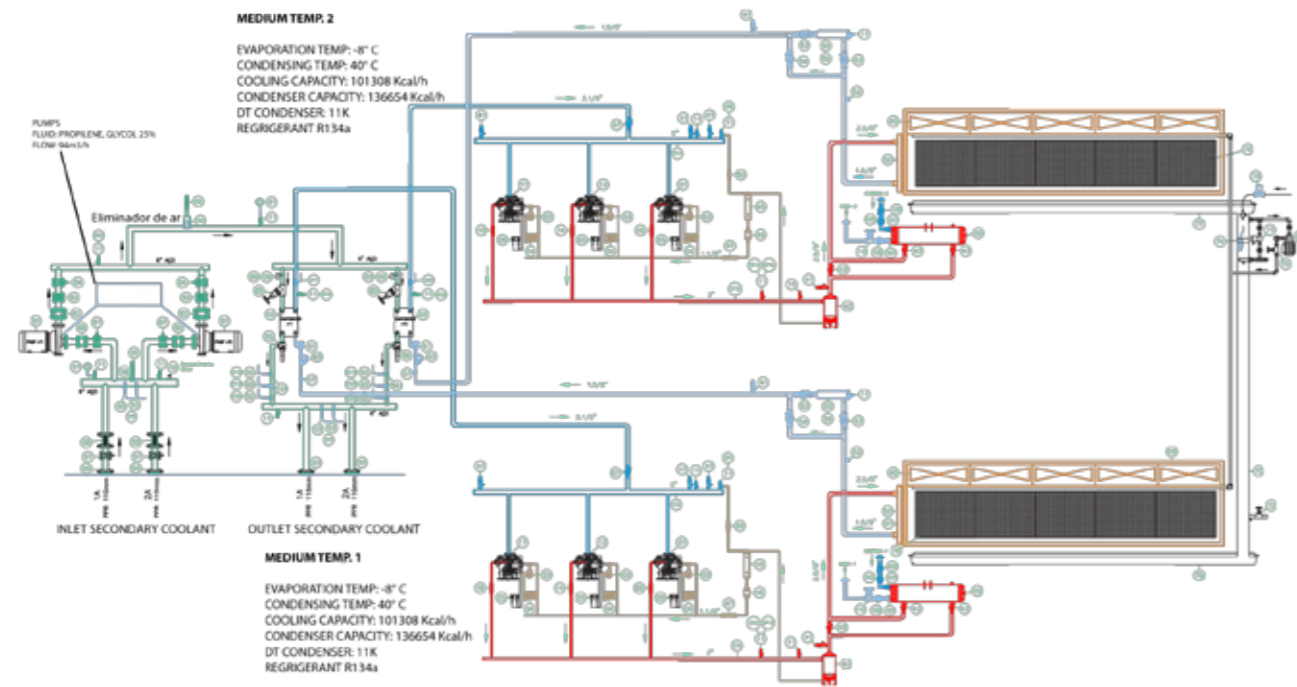

Fig.3 Medium temperature system diagram

Low temperature system diagram

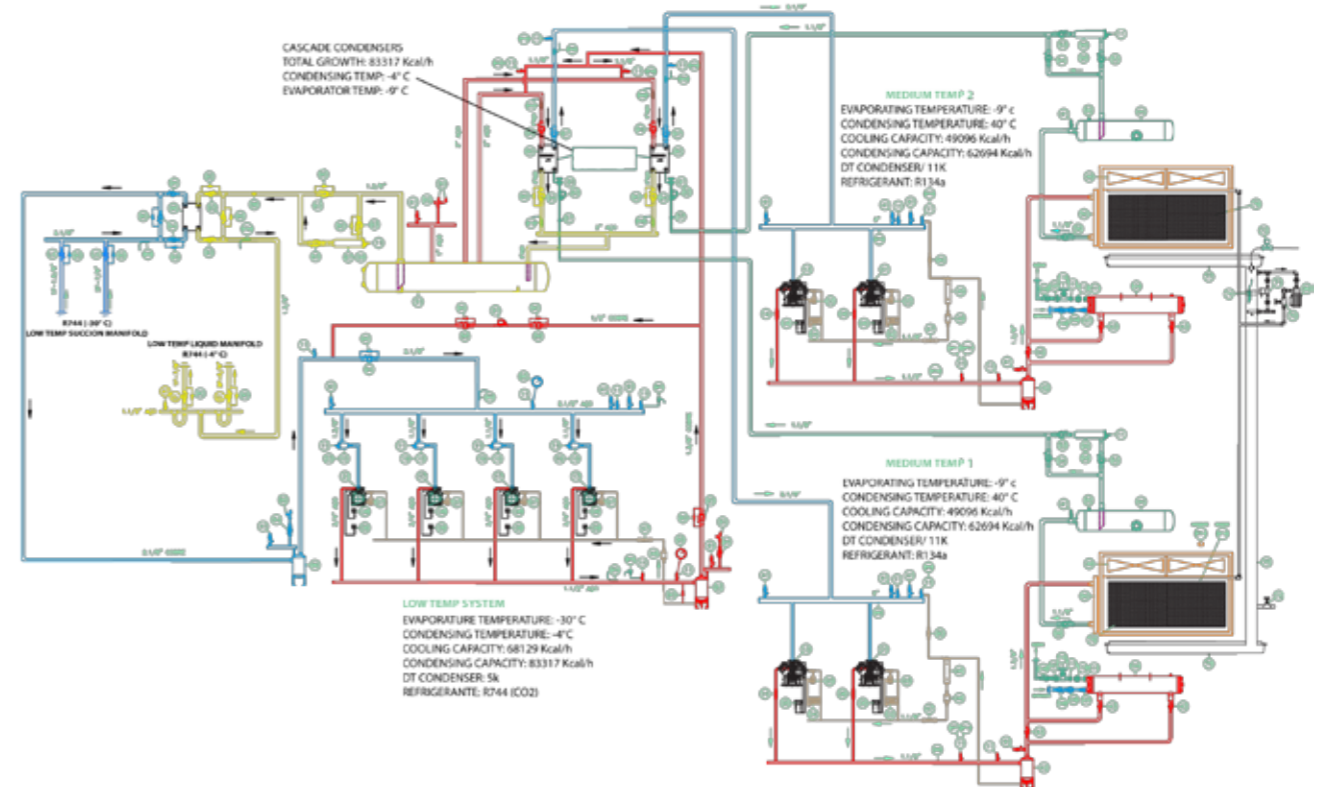

Fig.4 Low temperature system diagram

to maintain and operate as any other conventional refrigeration system.

Performance:

The overall achievement of this installation was a result of investment in training, equipment development and component research. The chosen components behaved as expected, allowing the optimal functioning of technologies to obtain the desired efficiency.

The resulting energy efficiency was 30% better, compared with the previous HCFC conventional systems. The main characteristics of the new CO₂ system are the adaptation of several high technology components in the global assembly such as:

- Intelligent two-speed ESM motors evaporation fans in refrigerated chambers and preparation areas, contributing also to a better ergonomic comfort.
- Progressively activated, variable speed EC motors in special aerodynamic designed ventilators in the condensing unit.
- iQ motors in liquid fluid evaporation grids, with very low energy consumption

The company acknowledges that at present while there is better availability of parts and components in the local market, facilitation of import of special parts and components from official authorities can be an important issue for the adoption of these new technologies. The main items required are R-744 compressors, intermediate heat exchangers, electronic valves and controllers. Fig. 5 shows a photo of the refrigeration system.

As R-744 is odourless, and its presence at levels greater than 10% is a serious health and safety issue, the company uses sensors and detectors in closed rooms and double release valves located in exterior locations as additional safety measures.

Cost and Economic Considerations:

Comparing the cost of the new system with conventional installations in the older stores, the company estimates



Fig. 5 The refrigeration system

a capital cost increase of 20%, taking into consideration the rack assembling, compressors, condensors, chillers, heat exchangers, evaporators, valves, piping, electric materials, command and control panels, hand work, start up and operation tests. However, this is offset by the reduced maintenance, operating and energy costs of the new system.

Comparison with older systems:

The payback of this system is less than 30 months. The maintenance cost was reduced by 40%. Energy savings are 30%.

One important aspect is that the energy reduction will be continuous, lowering costs and contributing to environmental benefits.

Disclaimer

The information presented here is provided by Supermercado Verdemar. The accuracy of the content and figures is the responsibility of the company and these have not been verified by the CCAC or UNEP.



CASE STUDY-10

Waitrose Commercial Refrigeration, UK

Name of the Store/facility:

Waitrose, Bromley South

Location:

Bromley, Kent, UK

Contact information:

Jim Burnett, jim_burnett@johnlewis.co.uk

Type of Facility:

Supermarket, Store Area = 2,170 m², Groceries, Food. Waitrose Limited is an upmarket chain of British supermarkets, forming the food retail division of Britain's largest employee-owned retailer.

Refrigerant Used:

Honeywell Solstice[®] ze, R-1234ze, HFO-1234ze. This case study has the world's first HFO chillers.

Project Background:

Bromley is near London and the store has a 2,170 m² sales area. The Bromley South store was opened in November 1996 and the plant was typical of systems built around that time. The existing system was R-404A and did not comply with the Waitrose policy of HFC reduction. Waitrose has signed on to the Consumer Goods Forums Resolution to start phasing out HFC refrigeration systems from 2015. Fig. 1 shows a photo of the store.

The new system is composed of two air-cooled HFO machines, each rated at 180 kW, which provide chilled water as a condensing medium for the in-store integral cases which run on propane. Waitrose is carrying out energy assessments on the chillers in the Bromley store to establish how they perform in relation to comparable chillers running on hydrocarbons. If the trial is successful as anticipated, Waitrose plans to adopt the HFO solution as part of its refrigeration platform for future stores.

Ambient conditions are typical of that around the UK and close proximity to London where the winter temperatures seldom fall below -4° C or rise above 14° C and the summer average temperature is 24° C.

The chilled water project was carried out in 2011



Fig. 1 Photo of the Waitrose store, Bromley South

whereby the existing compressor refrigeration packs were made redundant and the chilled water system installed.

Waitrose had decided on a water-cooled refrigeration system as these both reduced the refrigerant charges in the branch (as each cabinet is integral) and the potential for leakage due to water being at a lower pressure and systems being of a small individual charge.

Jim Burnett of Waitrose said: "We believe the HFO solution shows great promise, as it combines good efficiency with very low global warming potential. This is obviously a highly desirable profile in a refrigerant. If the ongoing monitoring of energy continues to prove successful, we plan to include HFO-based chillers in our choice of refrigeration platforms for stores in the future".

New System/Installation:

1,3,3,3-Tetrafluoropropene (HFO-1234ze) is a hydrofluoroolefin. Solstice[®] ze is a fluorinated gas from the HFO family that was developed as a "fourth generation" refrigerant to replace R-134a and other HFCs with high GWPs. HFO-1234ze has zero ozone-depletion potential and a low global-warming potential (GWP = 6).

Component selection information was very limited due to the pioneering use of this new refrigerant; reciprocating compressors were the only option at the time of installation.

The system is believed to be the world's first supermarket installation of a packaged chiller using an HFO refrigerant. The Italian-made Geoclimachillers are based on Frascold reciprocating compressors and operate on refrigerant HFO R-1234ze from Honeywell.

Schematic for the installed compressors

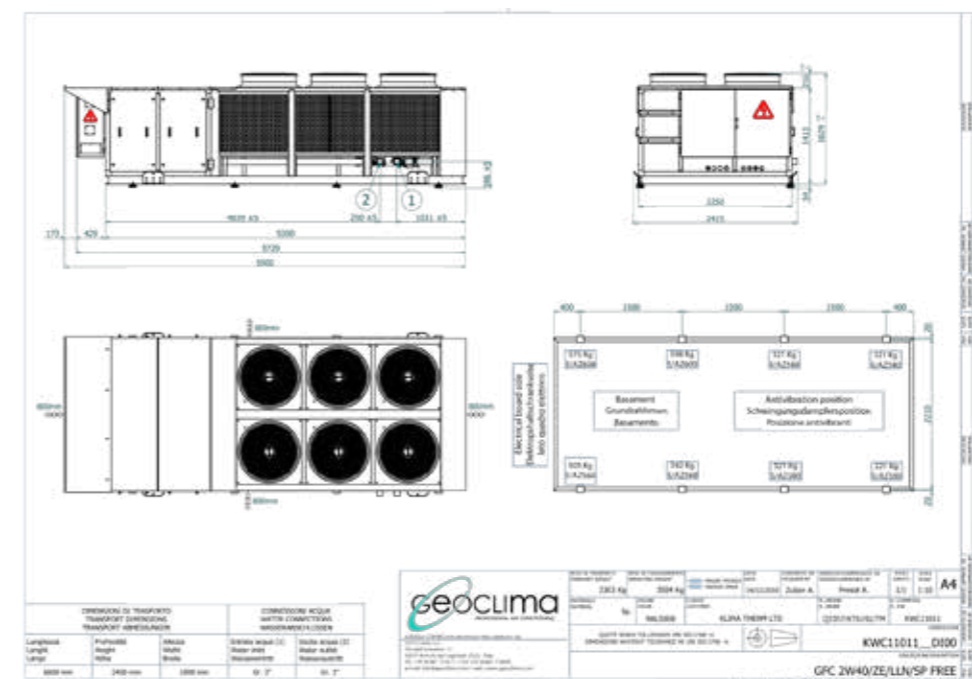

Fig. 2 Schematics for the installed compressors

Tipo / Type / Typ		N° di Matr. / Ser. Nr. / Ser. No.		Anno / Year / Jahr		N° ordine / Order / Auftr. Nr.	
Free - cooling water chiller		GEO1106003		2011		Q3357 / KT6192 / TM	
Modello / Model / Modell		Sch. / Wtr. / Sch.		P _{prov} / P _{prov} / P _{prov}		PS HP / PS LP / TS	
GFC ZW40ZE/LLN/SP		KWC11011 (I)		16,5 Bar / 05/09/11 / 15,0 Bar		7,0 Bar / -10,0 °C / 90,0 °C	
Carica refrigerante / Refrigerant charge / Kältemittelzufuhr		Tipo / Type / Typ		C1 / C2 / C3 / C4		kg / kg / kg / kg	
		R1234ZE (Gr. II)		25,0 / 25,0			
Max. corrente di lavoro / Max running current / Max. Betriebsstrom		Corrente di spunto totale / Total inrush current / Gesamte Anlaufstrom		Alimentazione principale / Main power / Betriebsstrom		Alimentaz. ausiliaria / Auxiliary power feed / Steuerstrom	
151,2		264,6		400 / 50 / 3 / N / PE		230 - 24 / 50 / 1 / PE	
Compressore / Compressor / Verdichter		Corrente nominale / Running current / Nennstrom		Corrente di spunto / Inrush current / Anlaufstrom		Alimentaz. princ. / Main power / Betriebsstrom	
1 / 23,2		41,2		215,0		400 / 50 / 3	
2 / 23,2		41,2		215,0		400 / 50 / 3	
Ventilatori / Fan motor / Lüfter		Volume aria condensatore / Condensator air volume / Verflüssiger Luftmenge		Prevalenza esterna / External pressure head / Zusätzliche Pressung			
6 x 0,84		6 x 1,4		14,2		400 / 50 / 3	
Peso di funzionam. / Operating weight / Betriebsgewicht		Carica olio / Oil charge / Inhalt je Kältekreislauf		Olio / Oil / Öl		PAG - 68	
3504 Kg		IP 44		8,0 kg			

Table 1 Specifications for the installed compressor

Fig. 2 shows schematics for the installed compressors. Its specifications are provided in Table 1. The total cooling capacity of the chillers was 360 kW with 21° C/15° C secondary fluid temperatures using 30% propylene glycol and 35° C air on temperature, split equally between two machines.

The refrigerant mass flow is 0.59 kg/s per compressor x 2 compressors per chiller x 2 chillers; each compressor is using 23.2 kW of power at full load; the design evaporating temperature is 11° C; the design condensing temperature is 50.5° C. The overall chiller energy efficiency ratio (EER) at full load is 3.50, but it

GFC R1234ZE (Waitrose)		KTC11011 TECHNICAL DATA	
MODELL		GFC 2W40ZE/SPILLN	
Design data :			
Cooling Capacity	kW	180	
Ambient Temperature	°C	35	
Refrigerant Circuits	n°	2	
Capacity Steps	n°	4	
Noise Level	dB(A) - 10m	50	
Refrigerant	Type	R1234ZE	
Refrigerant Charge (each circuit)	Kg	20.4	
Compressor	Type	Reciprocating	
EER	l	3.5	
Chiller performance :			
Entering Fluid Temp.	°C	21	
Leaving Fluid Temp.	°C	15	
Propylene Glycol	%	30.00	
Water Flow rate	m3/h	27.30	
Water Pressure Drop	KPa	100	
Free cooling mode :			
Total Cooling Capacity	kW	180.00	
Entering Fluid Temp.	°C	21	
Leaving Fluid Temp.	°C	15	
Ambient Temperature	°C	6	
Compressors :			
N° of Compressors	n°	2	
Nominal Power Input (each)	kW	23.20	
Running Current (each)	A	41.17	
Max Current (each)	A	71.40	
Starting Current (each)	A	215.00	
Condenser coil :			
Type	Type	Finned coil	
Pipe material	Type	Copper	
Fins material	Type	Aluminum	
Condenser EC Fan (max 735rpm) :			
Fans Diameter	Mm	800	
Fans Quantity	n°	6	
Total Fans Airflow	m3/h	51200.00	
Total Fans Motor Power Input	kW	5.0	
Evaporator :			
Evaporator Quantity	n°	1	
Type	Type	plate to plate	
Water Holding Volume(total)	Lt	163	
Evaporator Expansion device :			
Type	Type	electronic	

Table 2 System specifications and capacity

must be remembered that this is a free-cooling chiller, thus the fan energy consumption is relatively high due to the increased air resistance, but the overall annual energy consumption is relatively low due to this same free-cooling. Free-cooling chillers are designed when the need for cooling continues during colder ambient temperatures and that ambient temperature is lower than the return liquid temperature. In this case, there is a large potential to reduce the energy consumption of the liquid chillers by utilising the benefit of low ambient temperatures for substantial proportions of the year.

The system specifications and its capacity are presented in Table 2

Since it is the first application of this new refrigerant in the world, very limited performance and design information is currently available. The new system has performed as expected so far, but better optimisation of the compressor motor / swept volume arrangement could lead to better EER.

Performance:

Since installation this plant has been performing well and no failures have been reported.

The first chillers using the new HFO refrigerants were tried at Waitrose in this supermarket.

This refrigerant has a GWP of 6, i.e. double that of propane (GWP=3.3) but still very low compared with HFCs in general.

The evaporators used with HFO-1234ze should be oversized by around 6% compared to R-134a. There is no discernible difference in the required condensing coil area or air volume. The refrigerant lines need to be generously sized in the gas phase when using HFO-1234ze. The expansion valve sizing is effectively the same as R-134a. The extra cost of the HFO-1234ze compared to R-134a is offset by the lower volume of refrigerant, due to the use of DX evaporators with the HFO-1234ze to deliver the same efficiency as R-134a with flooded evaporator.

All the components have performed as anticipated. Spare parts for the system are available. The chillers using this new refrigerant run more efficiently than the hydrocarbon version that is currently used in other stores.

The system uses two 180 kW chillers with a Frascold semi-hermetic compressor supplying chilled water as a condenser medium for the in-store integral cases running on propane (R-290).

A comparison has been done with a same-size store in Canterbury (in south-east England) running identical systems, but using R-290 (propane) instead of HFO-1234ze. The comparison shows a 22% reduction in energy consumption for the HFO system compared to the propane one.

Tests carried out by Frascold with its eight-cylinder reciprocating compressors running on HFO-1234ze indicate a loss of capacity of around 24% compared with R-134a across various application conditions. However, mean power absorbed is almost 27% less, giving an overall COP actually better than R-134a across a range of applications and conditions.

The HFO R-1234ze technology is becoming more available now with more qualified servicing technicians being available. This new refrigerant is non-flammable at 20° C and only slightly flammable at 30° C. A flame will ignite it at 60° C. This refrigerant is treated as a non-toxic, mildly flammable refrigerant.

Cost and Economic Considerations:

The capital cost of the new system is currently approximately 10% more than a propane equivalent at the time of installation, but this cost is expected to go down as production is increased and as the operating characteristics and system design requirements become better understood. The cost of maintenance is the same as for hydrocarbon systems.

Disclaimer

The information presented here is provided by Waitrose. The accuracy of the content and figures is the responsibility of the company and these have not been verified by the CCAC or UNEP.

CASE STUDY-11

Application of Climate-Friendly Commercial Refrigeration Technologies: H-E-B, USA

Name of the Store/facility:

H-E-B at Mueller

Location:

Austin, Texas, United States

Contact information:

Charlie Wernette, wernette.charlie@heb.com

Type of Facility:

Supermarket, Store Area = 7,711 m²

Refrigerant Used:

Propane Self-Contained Cases

Project Background:

H-E-B has been incorporating sustainability measures into their stores for the past 15 years. As part of their environmental strategy for the H-E-B at Mueller sustainable design test store, H-E-B set a goal to reduce energy and potable water consumption by 50% relative to their 2010 baseline. In addition, H-E-B decided to trial the use of climate-friendly refrigerants.

Prior to the opening of their Mueller store, H-E-B had never used a non-fluorinated refrigerant. With the company's stores located in Texas (United States), and Mexico, H-E-B made a decision not to use a carbon dioxide (CO₂)-based technology, which operates at much higher pressures and therefore is not ideal for use in warmer climates. Inspired by Waitrose—a U.K.-based supermarket chain that began using propane-based refrigeration systems in their stores in 2009—H-E-B approached several equipment manufacturers in the United States about the possibility of implementing a similar type of refrigeration system in their stores. H-E-B ultimately decided to work with Hussmann, and in 2011, the effort to develop self-contained propane units was officially underway. Fig. 1 shows a photo of the store.

New System/Installation:

In total, the H-E-B at Mueller store contains 70 refrigerated cases that have a total cooling capacity of 1,013 MBTUs⁸. The majority of these cases are self-contained units that use propane (R-290) as the refrigerant. Each condensing unit contains a refrigerant charge size of no more than 150 g, as required by U.S. regulations, adding up to a total of 66.2 kg of propane within the store. The compressors, which pipe the refrigerant directly to the evaporator, are contained within each unit. The vast majority of the propane-refrigerated cases in the store have a door or sliding lid, which minimises energy consumption and allows the refrigerant charge to remain small.

In addition to the propane units, a small number of cases are cooled using a distributed direct expansion refrigeration system. This system, which uses R-404A as the refrigerant, is used to cool select produce cases that are not equipped with a door. These produce cases contain products that are kept wet with an automatic misting system, and therefore cannot be easily equipped with a door. Without a door, it would not have been feasible to keep the refrigerant charge of propane below 150 g; thus, H-E-B reverted to a more traditional refrigeration system to cool these cases.

All of the cases in the store are connected to a water-chilled condenser, which is used to remove heat from the refrigerant after it has removed heat from the refrigerated space. The water-chilled system, which is also used for space cooling and heating, contains 544.3 kg of HFC-134a. It is estimated that roughly 26% of the HFC-134a is used for refrigeration while the rest is used for cooling and heating.



Fig. 1 H-E-B at Mueller, Austin, Texas, United States. Photo courtesy of H-E-B by photographer Ray Briggs



Fig. 2 Deli Meat Cases. Photo courtesy of H-E-B by photographer Ray Briggs.

Other Sustainability and Energy Efficiency Measures:

H-E-B at Mueller is the seventh green building certified store by the company. H-E-B designed the store with several energy-saving features as well. LED lights are used throughout the store, both inside the cases and for overhead lighting. The roof is fitted with 169 kW of solar panels that provide part of the store's energy needs.

Performance:

Although the store has only been operational for a few months, the refrigeration system so far is operating as expected. While performance data was not available at the time that this case study was developed, it is projected that the carbon footprint of the store will be reduced by 85% relative to a baseline store. Of the 85% reduction, 58% is attributable to reduced energy use while the remaining 27% is attributable to the direct emissions avoided by using propane as the refrigerant.

From a financial perspective, the store cost more upfront but is expected to save money over time. While capital costs were relatively high, the simple, self-contained design eliminated the need to pay a refrigeration contractor to install the system. Due to the simple design, maintenance costs are also expected to be relatively low. Furthermore, cost savings will be realised through a reduced energy bill. H-E-B anticipates a payback on its investment in energy reduction and advanced refrigeration technology design features.

Challenges and Lessons Learned:

H-E-B has identified a variety of benefits associated with its refrigeration system. First, using propane instead of a traditional HFC refrigerant offers enormous environmental benefits. Propane has a global warming potential (GWP) of three, which is significantly lower than the GWP of traditionally used HFC refrigerants, which can be over 3,000. In addition, the simple 'plug-in' design, similar to a home refrigerator, is a major benefit.

The simple design allowed H-E-B to plug in the self-contained units and hook them up to the water-cooled condenser rather than having to purchase the display cases and refrigeration racks separately and hire a contractor to install the piping network, connect the system, and charge it with refrigerant and oil.

While H-E-B is very happy with the outcome of the store design, it did not come without some challenges. First, the United States Environmental Protection Agency restriction on charge size of 150 g of propane per unit required H-E-B, with the help of Hussmann, to develop a unique system design to accommodate the refrigerant. To compensate for the limited refrigerant charge, the resulting design uses significantly more compressors than a traditional system, which drives up costs. In addition, it was a challenge to overcome the stigma associated with using a flammable refrigerant. The store was required to install extra leak detection and alarm systems prior to receiving approval from the Austin Fire Department to operate.

Even with the challenges that H-E-B faced, they believe that the benefits of this store outweigh the costs; plans are underway to install the novel technology in other H-E-B stores.

Disclaimer

The information presented here is provided by H-E-B. The accuracy of the content and figures is the responsibility of the company and these have not been verified by the CCAC or UNEP.



SECTION 2:

TRANSPORT REFRIGERATION CASE STUDIES

Sector Overview

The transport refrigeration sector comprises the equipment, technologies and services used to transport and dispense frozen and fresh foods at the appropriate temperatures. Travel time, ambient temperatures, and risk of spoilage often make temperature controlled transportation necessary. Because some commodities are sensitive to the relative humidity and chemical composition of their surrounding atmosphere, these conditions may also need to be controlled. Today many commodities travel to distant markets intermodally (i.e., by some combination of highway, ocean and railroad).

Vehicles used for temperature-controlled transport are similar in construction and outward appearance to those in general freight service, but have three fundamental differences which are as follows:

1. Insulation that is usually foamed in place.
2. Provisions for conditioned air circulation through and around the cargo.
3. Machinery for cooling/heating.

A brief description of the four main vehicle types is as follows:

Cargo containers are usually 2.4 m wide, 2.4 to 2.9 m high and 6.1 or 12.2 m long. They have hinged doors in one end for cargo loading and other access to the interior. The machinery comprises the opposite end, so it must also provide structural rigidity and insulation. Containers have standardized corner fittings to secure them to vessels, railway cars, and highway vehicles.

Railway refrigerator cars are insulated boxcars, usually 15 to 20 m long. They may have a machinery compartment at one end.

Trailers range in size from 2.4 to 2.6 m wide, 3.7 to 4.1 m high, and 7.3 to 18.3 m long. Their doors are usually hinged, but they may have insulated roll-up doors if used for multi-stop delivery service. Some include a curb-side door in addition to rear doors. Several interior compartments for different temperatures may be provided by an insulated bulkhead to separate the

different zones. Specially designed trailers riding on railway flat cars are quite common.

As with ordinary trucks, those built for temperature-controlled duty come in a wide variety of designs and sizes. Their bodies may have insulated hinged or roll-up doors on the sides and rear. Truck bodies also may have several interior compartments for different temperatures, similar to trailers, with an insulated bulkhead separating the different zones. Smaller vehicles may include a refrigeration compressor as an engine-driven accessory.

Cargo Container and Rail Car Systems

Refrigerated cargo containers typically have unitary equipment that comprises the entire front wall of the container. The equipment has a vapour compression refrigeration system and uses an external source of electricity for its compressor and fan motors, resistance heaters, and operating controls. It usually uses bottom air delivery. The unit may have a detachable diesel engine/generator set (with integral fuel tank) accompany it while traveling by land. Rail cars may have field-installed components. A three-phase AC diesel engine-generator set, condensing unit, and refrigerant and electrical operating controls are usually located in a machinery compartment at one end of the car. An evaporator fan-coil package, or separately mounted evaporator and fan, is typically adjacent to the machinery compartment but inside the insulated space. Electric heaters in or under the evaporator are used for heating and defrost.

Self-Powered Truck and Trailer Systems

The majority of over-the-road transport refrigeration equipment is based on vapour compression technology. Whereas refrigerated cargo containers and railway refrigerator cars are supplied by external electric power, truck and trailer refrigeration units are designed with a range of driving concepts. Units can be self-powered or vehicle powered. The self-powered unit contains its own prime mover and therefore can operate independently on the vehicle.

A combustion engine is frequently used as a source of

mechanical power. In this case, the engine drives an open-shaft compressor and condenser and evaporator fans/blowers are driven through a belt-and-pulley system. This classical concept of a self-powered refrigeration unit is widely applied on truck and trailer systems. There is only one source of mechanical energy, and cooling capacity can be modulated either by switching the engine on and off, or by shifting engine speed between predetermined high- and low-speed operating modes. Engine speed change also changes the speed of the fans/blowers and therefore affects air circulation over the condenser and inside the refrigerated space.

An optional standby operation is often used in this type of system. An electric motor is integrated into the drive system so that when the vehicle is stationary, the refrigeration system can be operated by electric power, also referred to as shore power.

Another type of self-powered unit propulsion system uses an on-board engine-driven generator that supplies power to an electric compressor and to condenser and evaporator fan/blower motors. The full electric refrigeration unit allows for use of a hermetic or semi-hermetic compressor, thus eliminating potential for shaft seal leakage. The electric-powered components can be controlled independently, turning on and off when needed. Electric supply eliminates belt transmission losses, and the refrigeration unit can be directly connected to shore power when the vehicle is stationary.

Trailer systems typically have unitary equipment that consists of a diesel engine with battery-charging alternator, compressor, condenser and engine radiator with fan, evaporator with fan, and refrigerant and electrical controls. The refrigeration components, such as the compressor, condenser fan, and evaporator fan, can be mechanically driven from the engine. These components may also be fully electric, with the diesel engine driving a generator, or some combination of mechanical and electric components can be used. Large self-powered truck systems typically have unitary

equipment that is similar to trailer equipment.

Vehicle-Powered Systems

Vehicle-powered refrigeration units, as the name suggests, draw power from the vehicle's propulsion system. This type of system is typically applied to small trucks and vans used for local delivery of refrigerated products. For this type of system, the compressor can be mechanically driven, typically through a belt and pulley, from the engine, with all other refrigeration components driven electrically off the vehicle battery. As with self-powered trucks, a condenser and evaporator fan-coil package is installed at the front top over an opening to accommodate the evaporator and its fan(s), and top air delivery is generally used. An all-electric vehicle-powered truck system, is powered by an electric alternator that is driven by a belt either from the engine crankshaft or the engine power take-off (PTO). Electrical power is wired to the refrigeration unit, which allows use of a hermetic or semi-hermetic compressor and electric fan motors.

Multi-temperature Systems

Trucks and trailers with multiple interior compartments operating at different temperatures require a multi-temperature refrigeration unit. A moveable insulated bulkhead typically separates the different compartments, and remote parallel evaporators are connected to the main refrigeration unit, which is connected to the front wall.

The expected lifetime for all transport is between 10 and 15 years, and between 20 and 25 years for equipment aboard ships. Refrigerant charge size ranges from 4.5 to 7.5 kg for road vehicles, railcars, and intermodal containers and from 100 to 500 kg for conventional equipment aboard ships.

Historically, HCFC-22 was used for transport refrigeration applications which were converted to HFCs in the 1990s—primarily to R-404A, R-507A, R-410A, R-407C, and HFC-134a. Currently, significant research on zero- and lower-GWP refrigerants has focused on “natural” or non-fluorinated, chemicals such as CO₂ (R-744), NH₃ (R-717), Liquid Nitrogen (LN₂),

and hydrocarbons (HCs), as well as other man-made chemicals such as hydrofluoroolefins (HFOs). HFOs are a new class of unsaturated HFC refrigerants which have lower GWPs and shorter atmospheric lifetimes when compared to other HFCs. Some of the applications of these refrigerants in transport refrigeration are highlighted below:

REFRIGERANT	APPLICATIONS	CHALLENGES
CO ₂ (R-744)	Limited use in refrigerated ships and road applications- used in some small intermodal containers and boxes; requires external mechanical refrigeration system to generate.	Safety Risks, High Operating Pressure; Requires: Good Engineering Design and extensive Training and Education.
NH ₃ (R-717)	Limited application in indirect and cascade systems on new refrigerated ships; specifically in ships that carry professional crew only (no passengers) and those with relatively high refrigeration capacity (e.g., fishing ships). Under evaluation for use in refrigerated railcars, Rails and Ships.	Toxicity, Slight Flammability; Requires: Good Engineering Design, Standards and Safety Regulations.
HCs (e.g. isobutane, propane)	Under evaluation for use in road or rail transport refrigeration (in secondary loop systems). Use in compression systems (including hermetic/semi-hermetic compressors) likely to be enabled in road transport if/ when refrigeration equipment becomes electrified.	High Flammability, Liability Concerns; Requires: Safety Code Restrictions, Safety Devices, Standards and Service Procedures, Training and Education.
HFOs (e.g. HFO-1234yf, blends)	Under consideration for use across transport refrigeration modes beyond 2014, Intermodal containers, Rail, Road, Ships	Slight Flammability; Requires: Research and Development, Alternative Refrigerant Technologies
Liquid Nitrogen (LN ₂)	Limited use in cryogenic refrigerated units	Safety Risks, Requires: Good Engineering Design and extensive Training and Education.

To compile the case studies, research was conducted to generate a list of potential case studies for consideration taking into account all of the currently available zero- and lower-GWP refrigerants in transportation refrigeration applications. Some criteria such as geographic location, refrigerant used and available information of the proposed applications were taken into consideration when selecting the case studies. However obtaining appropriate and relevant case studies in the transportation refrigeration sector was something of a challenge. Included below are three case studies with CO₂ and LN₂ refrigerants with innovative technologies and systems in the field of transportation refrigeration. The intention is in the future to collate further case studies from other transportation sectors as well as examples of other lower-GWP refrigerants and advanced technological inventions, systems and strategies.

These chosen case studies take into account energy efficiency benefits of alternatives, as well as cost, safety, availability, maintainability, life expectancy and other sustainable and environmental considerations. Robust technical information was collected in the chosen case studies based on data provided by the source. These case studies also provide a detailed analysis for the system components, methodologies, and controls technology to optimise energy efficiency and continually update with new developments.

The technologies presented in these case studies are only some examples of the many available options for zero- and lower-GWP substances, taking into account all design criteria, such as system performance, environmental impact, and cost analysis. The cases presented here focus on CO₂, and LN₂ refrigerants.

All these refrigerants still have many challenges that should be considered in the design such as their flammability, toxicity, lower efficiencies in some cases, and cost. Balancing the safety, energy efficiency, cost, and environmental impact of refrigerants using a consistent and comprehensive methodology across all refrigerants and system types is essential in assessing

alternatives. Good design is also important for reducing refrigerant emissions and preventing refrigerant loss during installation, operation and maintenance, decommissioning and end-of-life disposal.

CASE STUDY-1

ASKO, Norway

Name of the Facility:

ASKO, Norway

Location:

Norway

Contact information:

Name: Dr. Dermott Crombie

Email: dermott_crombie@thermoking.com

Designation: Vice President, Strategic Initiatives, Climate Solutions

Transport Category:

Road transport

Refrigerant Used:

Liquid CO₂/R-744

Project Background:

Urbanisation is a global phenomenon. Today, in the EU, 70% of the population lives in cities⁹, and this percentage will continue to increase. Major urban centres are working to improve the quality of life for their inhabitants. One measure of success is the extent to which lifespan can be extended.

Contributing factors would include road safety, exercise, air quality, noise, and diet. On this last point, it is worth noting that prior to the invention of transport refrigeration (1938) people in the developed world ate fresh food, in season, grown within 100 miles of where they lived. Outside of those parameters, people ate dried, salted or pickled food. Today, people in the developed world eat almost any type of fresh perishable food, any day of the year. Strawberries at Christmas, kiwis from half way around the world, are all taken for granted. A varied and fresh diet has contributed greatly to the health of the general public.

This study outlines a product which provides near-silent, zero-emissions refrigeration, ideal for distribution of perishables both day and night in busy urban locations.

ASKO is a major retailer in Norway. With 3,300 employees, and a turnover of over 50 billion Kr in

2014. ASKO includes 13 regional ASKO companies, central warehouses and a cross docking terminal at Vestby in Akershus, plus 8 Storcash outlets. Storcash is the largest cash & carry wholesale for businesses. With 600 trucks on the road each day, ASKO is also one of the largest transport companies in Norway.

New System/Installation:

The challenge of delivering perishables to large urban centres with minimal environmental impact is addressed in this case study. Traditionally, refrigerated trucks, running on diesel fuel, used an additional diesel-powered refrigeration system, operating with hydrofluorocarbon (HFC) refrigerants, to make regular deliveries to city supermarkets. The novel cryogenic system discussed here can operate on a traditional diesel truck, or on an electric vehicle. The system operates without utilizing HFCs, requires no diesel engine, thus avoiding other emissions, including particulates (PM), and does so almost silently (59 dBA or lower).

United Nations World Urbanisation Prospects: The 2014 Revision, Highlights

The system utilises waste CO₂ (carbon dioxide), typically from fertilizer, ammonia production processes or more and more from biological processes such as the conversion of biogas into Natural Gas. The energy used to refrigerate the cargo has to originate somewhere. In this case, the energy for liquefying the CO₂ comes from the national electricity power grid. Other cryogenics such as LN₂ (liquid nitrogen) were considered but were rejected for reasons we will discuss later.

Schematic Diagram of the Thermo King Refrigeration System

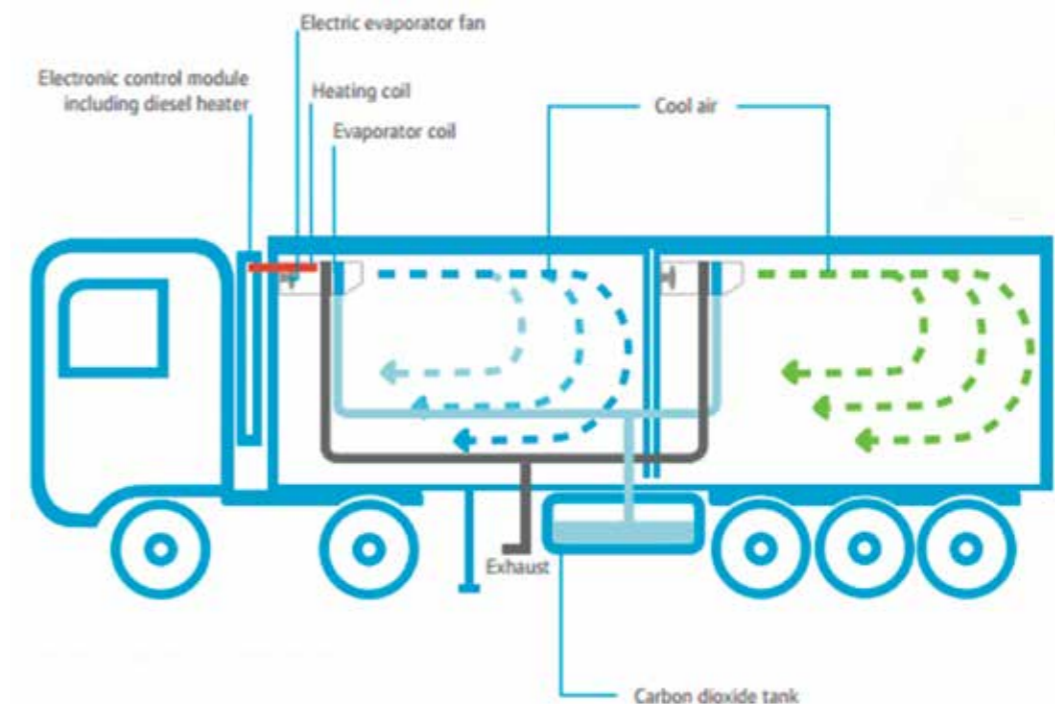

Fig. 1 Schematic Diagram of the Thermo King Refrigeration System

The liquid CO₂ is stored in a cryogen tank, fitted on the vehicle. The system utilises a liquid CO₂-fed evaporator coil in the load space to remove heat from the cargo. The liquid CO₂ does not enter the cargo space. A fan system is powered by the vehicle's electrical system. Earlier systems used the cryogen to power the fan system as well, but this configuration was less effective because the fan system only ran when cooling was required. The latest system has air circulation independent of cooling demand, which leads to a better control of the cargo climate, and better utilisation of the cryogen in the tank. Fig. 1 shows a schematic diagram of the refrigeration system.

Reduced Carbon Footprint

CryoTech uses liquid carbon dioxide (CO₂ or R-744), sourced from recycled waste gas. R-744 is a waste by-product of industrial processes which avoids a cumulative global warming effect. Liquefaction of R-744 generates significantly less emissions than nitrogen or fossil fuels. Fig. 2 shows a source path of liquid CO₂.

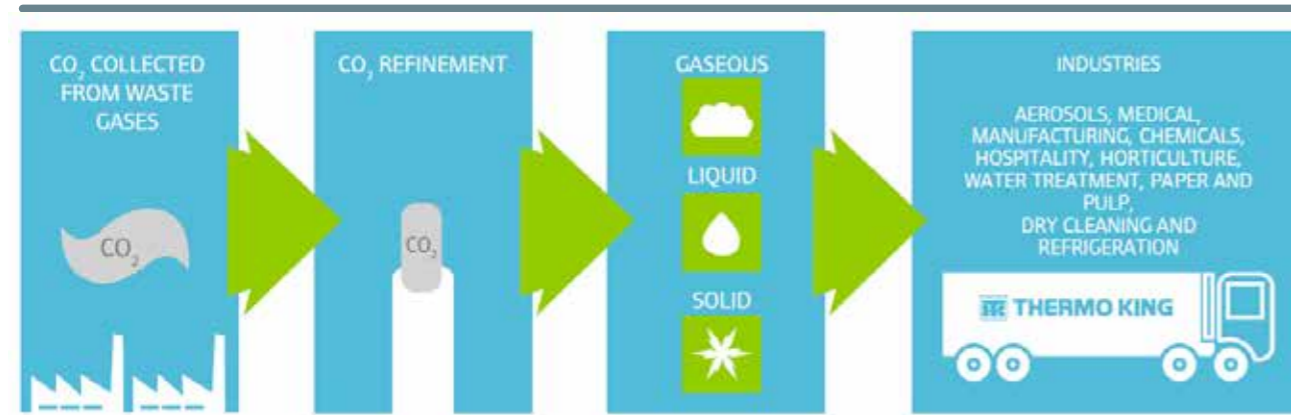

Fig. 2 Source Path of liquid CO₂

Choice of Cryogen:

Thermo King looked at several cryogenes including CO₂ and LN₂. Liquefied air is sometimes mentioned, but in practice the 21% O₂ contained in liquefied air is removed and sold separately, leaving ‘liquefied air’ cryogen as LN₂. LN₂ has a much lower cryogen temperature, being stored at degrees -196°C, whereas liquid CO₂ is stored at degrees -57°C. In this respect, LN₂ presents more of a safety challenge than R744. Additionally, liquid CO₂ has higher refrigeration capacity per stored litre of cryogen, meaning the cryogen tank can go farther on CO₂ than on LN₂.

Finally, the carbon footprints of LN₂ & liquid CO₂ are compared below with a traditional diesel system as a reference. Fig. 3 shows an annual average CO₂ Emissions from Truck Unit Operation.

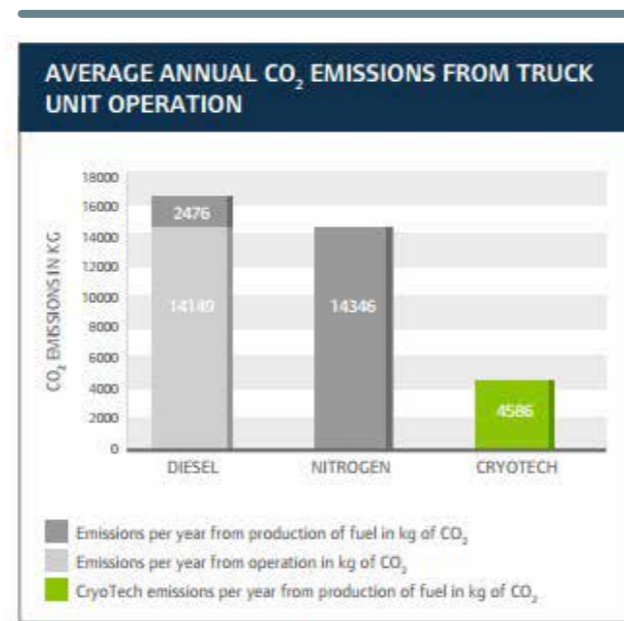

Fig. 3 Annual Average CO₂ Emissions from Truck Unit Operation

Multi-compartment:

Inner city supermarkets carry a wide range of perishables, which need to be transported at a variety of temperatures. To minimise the number of vehicles delivering, Thermo King has developed the Cryo product range to include up to three independent temperature compartments in one vehicle. Thus, one vehicle can deliver fresh, chilled, and frozen food in one delivery, thereby reducing traffic volumes.

CO₂ Storage:

CO₂ is stored in a large tank, either at a public filling station, Thermo King Dealer facility, or at the customer’s distribution centre. Liquid CO₂ is ‘refueled’ as needed, typically on a daily basis. Fig. 4 shows a photo of the CO₂ tank.



Fig. 4 CO₂ tank

Noise:

Noise has been identified as a key element in quality of the environment. Fig. 5 gives an indication of sound pressure level of various systems and equipment.



Fig. 5 Sound Pressure values of various systems and equipment

Fig. 6 chart illustrates the dramatic noise difference when compared to traditional diesel refrigeration units.

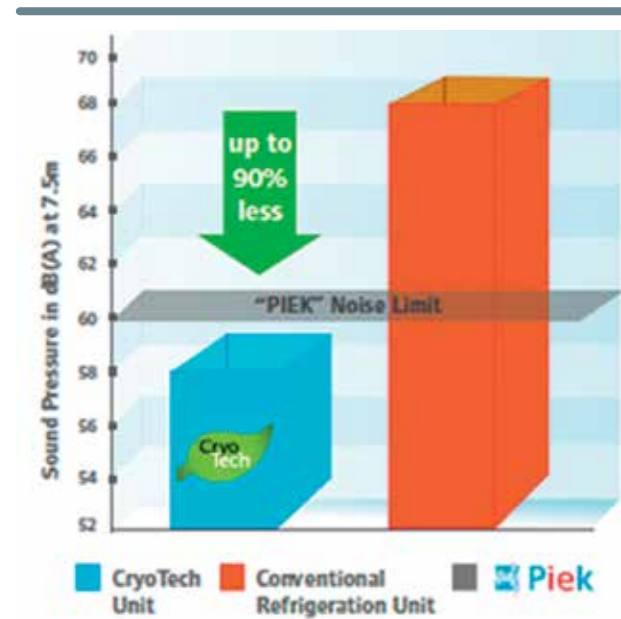

Fig. 6 Sound level comparison between Cryotech unit and conventional Refrigeration Unit.

Due to the very low noise levels of the system, they are suitable for delivering at night. Doing so allows a shift from busy daytime traffic to times when traffic is much lighter, again saving on distribution time and fuel used.

Performance:

A major factor in shelf life of perishables is in maintaining their correct temperature. Fast recovery of the correct temperature after the doors have been opened multiple times is key to cargo quality. In this respect, the Cryotech system outperforms the traditional refrigeration system, as it has fewer constraints on cooling capacity. Fig. 7 shows the pull down comparison of Cryotech unit and Conventional Refrigeration Unit.

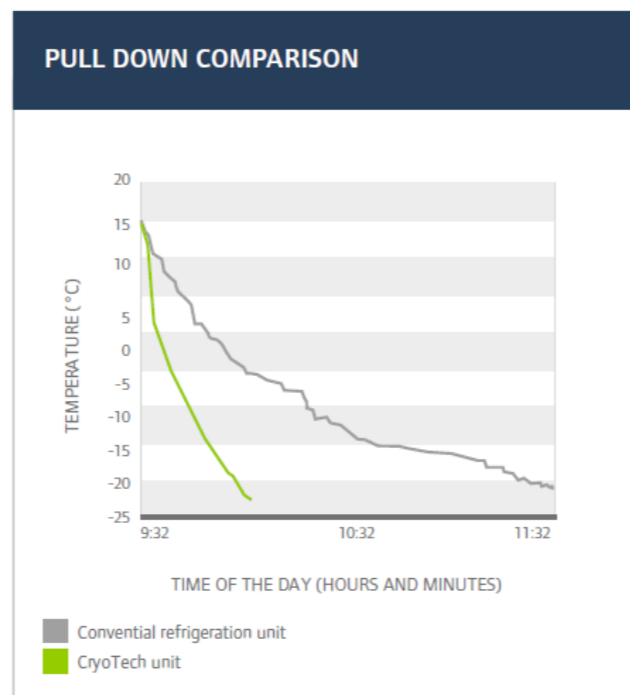

Fig. 7 Pull down Comparison of Cryotech unit and Conventional Refrigeration Unit

Shelf Life and Reduced Waste:

Both fresh and frozen products can suffer significant temperature fluctuations every time a drop is made. Such spoilage can account for 0.25% of a retailer's annual turnover¹⁰. With its market leading temperature recovery, Cryotech ensures steady product temperature even on the most demanding distribution routes at high ambient temperatures. Fig. 8 shows a comparison of shelf life and reduced waste between Cryotech unit and Traditional Refrigeration unit.



Fig. 8 Shelf life and Reduced waste comparison between Cryotech unit and Traditional Refrigeration Unit

Uncompromised freshness, longer shelf life and reduced spoilage mean you can optimise retailers' inventory and economics of transportation and storage of perishables.

Cost and Economic Considerations:

The capital cost of the new system is currently higher than the traditional diesel powered system, as it involves installing a cryogen storage system at the depot. However, running costs are lower resulting in an overall savings of around 7% in overall costs.

Case studies have shown that city distribution during rush hours take, on average 14% more time. Cryotech allows you to access restricted areas at any time during the day or night, due to its very low noise levels. Avoiding heavy traffic with faster distribution runs saves time and cuts fleet operating costs by up to 7%. Fig. 9 shows a distribution pattern and savings with Cryotech units.

Distribution pattern and savings*



Fig. 9 Distribution Pattern and Savings with Cryotech Units

Disclaimer:

The information presented here is provided by Thermo King. The accuracy of the content and figures is the responsibility of the company and these have not been verified by the CCAC or UNEP.

¹⁰Spar, Netherlands

CASE STUDY-2

Carrier Corporation, USA

Name of the Company/Facility:

Carrier Corporation, a part of UTC Building & Industrial Systems,
A unit of United Technologies Corporation

Location:

Syracuse, NY USA

Contact information:

Name: Jim Taeckens
Email: James.Taeckens@carrier.utc.com
Designation: Product Manager, Container Products Group

Transport Category:

Transport Refrigeration - Container
Refrigeration System type: Cryogenic System

Refrigerant Used:

Carrier's NaturaLINE unit utilizes CO₂ (R744) as its refrigerant.

Technology Transition:

For the Container application, Carrier has traditionally used HFC-134a for its relatively low GWP (Global Warming Potential) in an HFC (hydrofluorocarbon) based design, as well as overall efficiency, capacity, cost and availability. Fig. 1 shows a comparison of various container installed base refrigerants.

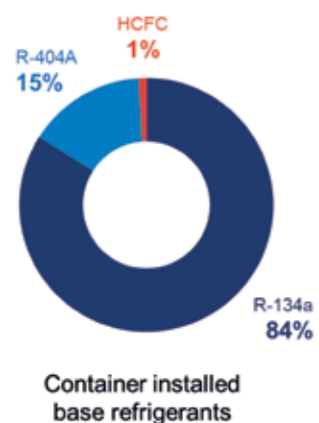

Fig. 1 Comparison wheel of various container installed base refrigerants (Carrier Internal Estimate)

As governments and environmental advocacy organizations are considering regulations around HFC refrigerants due to concerns about global warming potential, the desire for natural refrigerants as a solution are needed for sustainable refrigerated transport. For the introduction of our NaturaLINE® unit, the world's first natural refrigerant Container unit, we decided to use Carbon dioxide CO₂ (R744) based on the same criteria of Global Warming Potential (GWP), cost, efficiency, capacity and availability.

Project Background:

Carrier Transicold helps improve transport and shipping of temperature controlled cargoes with a complete line of equipment and services for refrigerated transport and cold chain visibility. For more than 40 years, Carrier Transicold has been an industry leader, providing customers around the world with the most advanced, energy-efficient and environmentally sustainable container refrigeration systems and generator sets, direct-drive and diesel truck units, and trailer refrigeration systems. Carrier Transicold is a part of UTC Climate, Controls & Security, a unit of United Technologies Corp. (NYSE:UTX), a leading provider to the aerospace and building systems industries worldwide.

Carrier's NaturaLINE system underwent extensive field trials beginning in 2013 and through the end of 2014. These trials were conducted on a global basis with a number of customers, including container shipping lines as well as supermarket retailers testing the system for over the road use. Cargo transported range from frozen goods such as ice cream, carried at -22 degrees Celsius, to perishable goods such as bananas carried at 13 degrees Celsius. The trials represented over 120 shipments in total and accumulated more than 28,000 operating hours. The ambient temperatures experienced during these trials are representative of what container units normally experience, with ranges between -40 degrees Celsius to 50 degrees Celsius.

Original System:

Container refrigeration units are mobile systems designed to fit into a refrigerated ISO¹¹ container, typically 20 or 40 feet in length, that travel intermodal for transport on ships, rail and over the road. They typically consist of a basic vapour compression system utilizing a compressor, expansion device, evaporator (coil with fan & motor) and condenser (coil with fan & motor). Container refrigeration units can be configured with either reciprocating or scroll compression technology depending on customer preferences. The compressor can typically make up more than 50 percent of the total system energy consumption, during part-load operation, while the air circulating fans contribute another 12-15 percent. However, how these components are arranged, designed and controlled play a significant role in the overall efficiency of the unit. Fig. 2 shows a typical container refrigeration application.

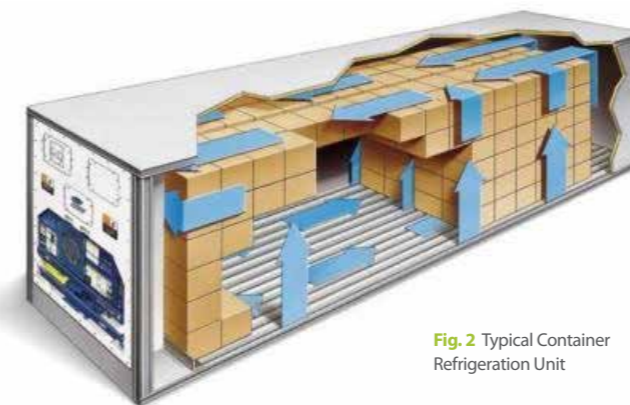

Fig. 2 Typical Container Refrigeration Unit

Environmental and efficiency concerns have been central to container refrigeration use and design for the last few decades. Advances in components and controls have delivered efficiency improvements along with refrigerant changes from ozone depleting CFC-12 to non-ozone depleting HFC-134a in the mid 1990's. At a typical rating point of -18C/38 deg. C the Coefficient of Performance (COP) has improved from 0.7 with a HCFC-12 system to 1.2 with the latest Carrier design using HFC-134a which is shown in the Bar Chart in Fig. 3

Energy efficiency improvement (@ 38°C/100°F ambient)

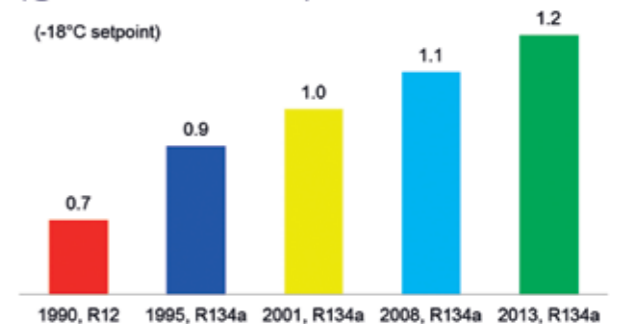

Fig. 3 Coefficient of Performance (COP) improvement for HFC-134a from 1990 to 2013

Today, the industry is becoming more focused on further improvements to reduce the GWP of container shipping both from a direct and indirect perspective. Global warming is influenced by both direct emissions from the refrigerant used and the energy consumption that is required to operate the machine. Both of these factors must be considered to achieve maximum emission reductions.

New System/Installation:

For container shipping, CO₂ is the only refrigerant that offers a GWP of one, avoids harmful direct emissions, has zero ozone-depletion potential and is classified as non-toxic and non-flammable. Further, is classified as an A1 refrigerant (no flame propagation, low toxicity), requires no disposal, is cost effective, available worldwide, and has excellent heat transfer and heat reclaim properties. Finally, CO₂ refrigerant is protected against phase-outs, taxes and F-gas regulations.

The challenge to create a system for transport refrigeration that meets the energy consumption levels of today's efficient HFC machines is significant. In order for CO₂ to work as a viable refrigerant it must meet the demands of energy efficiency, cooling capacity, power consumption and pull-down that are expected in a container refrigeration unit today. To do that, we had

¹¹ International Standard ISO 1492-2:2008 "Freight and Thermal Containers - Specification and Testing"

to develop components and systems that can better control capacity and temperature using CO₂.

Carrier's NaturaLINE system utilizes a variety of new technologies to meet this challenge and provide a solution for today's needs. These include:

- A multi-stage, exclusive, reciprocating compressor design that maximized capacity while minimizing power consumption
- A variable speed drive that is custom-designed to electronically adjust the compressor speed to provide required cooling capacity
- A gas cooler coil that was designed to wrap around the fan to maximize heat-transfer surface area for greater efficiency
- A flash tank added to the design to manage the flow and phase change of the refrigerant
- Two-speed fans for both the evaporator and gas cooler for greater energy saving performance
- Advanced software controls to manage the unique system and provide optimized performance
- A Zero GWP polyurethane (methyl formate) foam blowing agent is used for high insulation without contributing to GWP

The result is a system that offers high overall performance with efficiencies comparable to the highest selling unit available, as well as part-load, perishable performance efficiency greater than the best-selling HFC machine.



Fig. 4 Photo of Carrier's NaturaLINE System

Performance:

The capacity and efficiency of Carrier's NaturaLINE unit is comparable to Carrier's HFC units available today including the best-selling Carrier PrimeLINE™ unit. Specific capacity figures for typical rating points of a 38oC ambient and 60Hz power are:

2°C:	9400 W
-18°C:	6000 W
-29°C:	4400 W

The average energy usage for the NaturaLINE unit is similar to HFC-134a units, but with superior efficiency at part-load perishable set-points. A comparison against HFC-134a can be seen in Fig. 5.

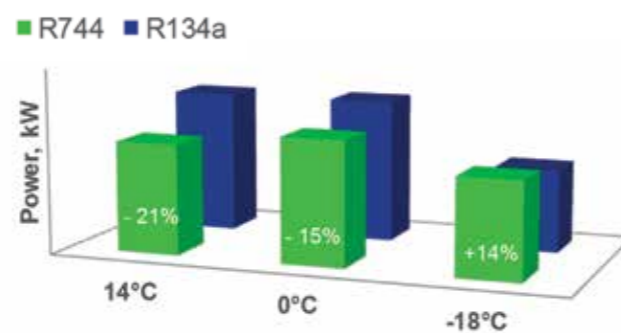

Fig. 5 Power Consumption comparison of R744 and HFC-134a

This represents average part-load energy use for a variety of conditions including perishable cargos (14 degrees Celsius, 0 degrees Celsius) as well as frozen (-18 degrees Celsius). You can see from the comparison that our NaturaLINE unit outperforms our PrimeLINE® unit (HFC-134a) in part-load perishable conditions, while the PrimeLINE unit outperforms in part-load frozen conditions. For a large shipping line, operating globally with a variety of cargo the net power consumption will be very similar for NaturaLINE and PrimeLINE units.

Carrier's NaturaLINE system is available worldwide today. Throughout the trial and pre-commercial phase, training was delivered on a global basis so industry participants would be ready for the new system. The NaturaLINE unit is as easy to operate and service as all other Carrier Transicold container refrigeration units, which are considered to be industry standard. While the NaturaLINE system incorporates new technologies to optimize refrigerant performance, the basic frame, evaporator fans, evaporator and the controller are based on proven Carrier Transicold models.

One key difference between traditional refrigeration units and the NaturaLINE unit is that the CO₂ refrigerant-based system operates at higher pressure than HFC-based systems – up to 1,800 psi (125 bar) compared to approximately 300 psi (22 bar) for an HFC system. To accommodate higher pressure, the NaturaLINE system's rugged design and construction helps assure its safety and reliability. For example, refrigerant tubes and other system components use thicker-walled material. The NaturaLINE unit's design adheres to the EN378-2 standard¹², and components are tested at pressures well beyond the maximums the unit will see in service use.

With regard to operating pressures, there is virtually no difference in servicing a NaturaLINE unit and traditional Carrier Transicold units using pressurized HFC refrigerants. The same precautions apply.

Cost and Economic Considerations:

The operational cost of the NaturaLINE unit will be comparable to existing HFC systems with respect to energy costs. Other costs associated with maintenance may be less as restrictions on HFC refrigerants and the cost of the higher GWP refrigerants rise either due to supply or taxation effects. Upfront costs will be more, but this is off-set by potential operating savings as well as potential risks associated with fleet obsolescence brought about by F-gas regulations that could be enacted in the future.

Disclaimer:

The information presented here is provided by Carrier Corporation. The accuracy of the content and figures is the responsibility of the company and these have not been verified by the CCAC or UNEP.

¹²European Standard EN378-2:2008 "Refrigeration Systems and Heat Pumps – Safety and Environmental Requirements"

CASE STUDY-3

EcoFridge Production Company Ltd, Ukraine

Name of the Company/Facility:

EcoFridge Production Company Ltd

Location:

Kharkov, 61085, Ukraine

Contact information:

Name: Kostyntyn Gavrylov

Email: kons.gavr@gmail.com

Designation: Managing Director

Transport Category:

Motor transport (trucks and trailers)

Refrigerant Used:

Liquid Nitrogen LN₂

Project Background:

Reduction of CO₂ emissions with high global warming potential (GWP) option at temperature controlled transport operation can be achieved by improvement of fuel quality and decrease of fuel consumption. For diesel-powered refrigeration transport, there are two sources of CO₂ emissions: one due to diesel combustion and second due to leakages of refrigerants. According to estimations^{13,14}, mechanical system releases 2.94 kg CO₂ for each litre of diesel fuel including extraction, refining, transportation and combustion and refrigerant leakage can add 5.1 tonnes eq. CO₂/yr to the total CO₂ emissions resulting in 3.53 kg CO₂ for each litre of diesel fuel.

Due to these disadvantages and government regulations on CO₂ emissions, industry is actively searching for viable alternatives to diesel technologies by development of more fuel efficient diesel engines and hybrid systems.

Hybrid-diesel units consist of a full-capacity diesel engine combined with an electric standby unit, which is used to maintain temperature when the truck/trailer is stationary and has access to a 3-phase electric outlet. An electric standby unit adds more weight to the truck and are 10% more expensive than diesel units.

Efforts to solve problems that could not be solved by

improving diesel systems and the creation of hybrid systems has led to the creation of cryogenic refrigerated units that use cryogenic technologies with liquid nitrogen (LN₂) or liquid carbon dioxide (L-CO₂)

There are two approaches to cryogenic refrigerated units design: direct cryogenic refrigerated units where N₂ is released into the load space for cooling and indirect cryogenic refrigerated units that use a heat exchanger with LN₂ or L-CO₂ to cool air circulated in the load space.

N₂ is an inert gas, constituting the largest part of the atmosphere so is harmless, however in direct refrigeration units, there is risk if operators enter an oxygen-free load space and hence require various safety measures to guard against personnel entering or being trapped in an area where oxygen is low or non-existent.

Safety concerns regarding the absence of reliable safety system for N₂ direct cryogenic refrigerated units was one of the reasons for well-known gas supplier Linde Gas Company to develop N₂ indirect cryogenic refrigerated units for truck and trailer use. This system uses LN₂ in a closed system as the coolant. Another CO₂ indirect cryogenic refrigerated units using L-CO₂ as refrigerant was developed by a major manufacturer. At prices of £1.0 (≈US \$1.4) per litre of diesel and £0.1 (≈US \$0.14) per kg of L-CO₂ there is no clear-cut economic advantage for such systems comparing to conventional diesel system. While CO₂ is less harmful than using diesel and HFCs as refrigerants, is still has significant GWP.

EcoFridge Production Company Ltd, located in Ukraine has 5 years ago launched a modified natureFridge N₂ direct cryogenic refrigerated units with economic consumption of LN₂ as coolant. Development of the unique safety system installed in natureFridge units allows realizing advantages of N₂ direct cryogenic refrigerated units and ensuring its safe operation to guard against personnel entering or being trapped in an area with gaseous N₂ atmosphere and very low oxygen content.

Analysis of the natureFridge units for refrigerated food transport has shown that it is feasible to use N₂ direct cryogenic refrigerated units for food transport refrigeration for both rigid vehicles and trailers at zero GHG emissions at its operation.

New System/Installation:

The natureFridge N₂ direct cryogenic technology suggests a "total loss": refrigerants technology as an alternative to mechanical refrigeration where after use the refrigerant is released to the atmosphere, hence the term "total loss".

LN₂ is an industrial non-toxic gas, which does not produce direct CO₂ emissions at its release to the atmosphere. There are only indirect CO₂ emissions due to electricity consumption at LN₂ production (different for different countries). Table. 1 presents comparison of the CO₂ emissions for modern mechanical system and any direct or indirect LN₂ system.

natureFridge technology provides refrigeration within the trucks' trailers' cargo space by means of a system consisting of a mounted storage tank, evaporator with sprayer above the cargo space and a thermostatically operated control system to inject N₂ as required. The operating control system is connected with temperature sensors, positioned in the interior space to be refrigerated. By means of apposite control valves the LN₂ flows to spryer which allows N₂ to be injected into the cargo space as a gas.

	LN ₂ SYSTEM	MECHANICAL SYSTEM	
Calculation for modern mechanical and natureFridge systems	N ₂ or diesel consumption (liter per hour)	15	1.8
	CO ₂ emissions (kg/h)	4.80 at emission factor 0.32 kg CO ₂ eq /l according to electricity consumption at LN ₂ production in USA	6.35
	CO ₂ saving	24%	
	CO ₂ emissions (kg/h)	0.96 at emission factor 0.064 kg CO ₂ eq/l according to electricity consumption at LN ₂ production in France	6.35
	CO ₂ saving	85%	
According to http://large.stanford.edu/publications/coal/references/docs/sae98.pdf	CO ₂ emissions (kg/h)	3.16 at emission factor of 0.21kg CO ₂ eq /l according to 0.405 kwh/l electricity consumption at LN ₂ production	6.35
	CO ₂ saving	50%	
According to http://www.globalcoldchainnews.com/Global_Special_Report-Cryogenics.pdf	N ₂ or diesel consumption (litre per hour)	26.17	2.79
	CO ₂ emissions (kg/h)	1.94 at emission factor of 0.386 kg CO ₂ eq /kwh according to 1.1 kwh/Nm ³ electricity consumption at LN ₂ production	7.82 (5.03 for hybrid system)
	CO ₂ saving	75% (61% for hybrid system)	
According to Air Liquid data	N ₂ or diesel consumption (litre per year)	89,467	14,470
	CO ₂ emissions (kg/h)	11.4 at emission factor 0.32 kg CO ₂ eq /l according to electricity consumption at LN ₂ production in USA	19.04
	CO ₂ saving	40%	
	CO ₂ emissions (kg/h)	2.24 at emission factor 0.064 kg CO ₂ eq /l according to electricity consumption at LN ₂ production in France	19.04
	CO ₂ saving	88%	

Table 1 CO₂ emissions for diesel (without leakage included) and natureFridge systems

More in depth the system lays together five operational subsystems (see Fig.1):

- Supply subsystem: it allows the possibility to install one to two tanks for the liquid nitrogen storing, which can be filled both from a supply track and a stationary supply tank.
- Control subsystem:
- Power subsystem:
- Cooling subsystem, which is equipped with:
- Safety subsystem, with multiple controls to minimize nitrogen asphyxiation risks

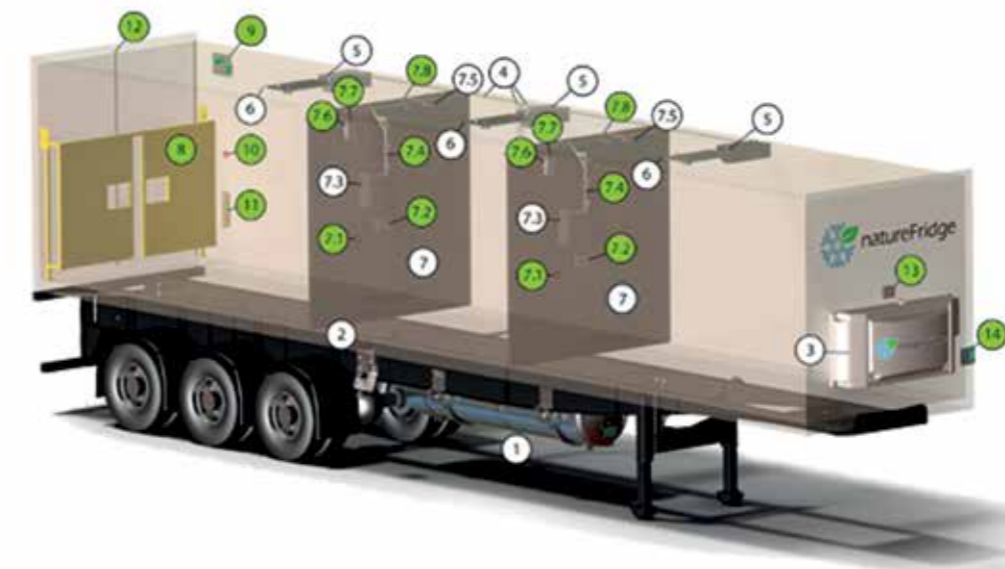

Fig. 1 Components of natureFridge system

Refrigeration Unit Components:

- ① Vessel Block ② Filling Unit ③ Control Block Box ④ Nitrogen Pipe ⑤ Sprayer Unit ⑥ Temperature Sensor Unit ⑦ Bulkhead
⑧ Electric Lock ⑨ Pusher.

Refrigeration Unit Components, Directly Related to Safety:

- ① Vessel Block Safety Components: Mechanical Safety Relief Valve, Economizer Safety Relief Valve, Safety Burst Disc "OSECO", Electric Solenoid Safety Drain Valve, Vessel Control Unit, Digital Differential Pressure Sensor ③ Control Block Box Safety Components: Safety Control Board, Safety Patch Control Board, Independent Safety Relay (w/o microprocessor) Din 8915 ⑦ Bulkhead Safety Components ⑦.1 Emergency STOP Button ⑦.2 Oxygen Sensor ⑦.4 Bulkhead Stopper ⑦.6 Oxygen Light Panel ⑦.7 Oxygen Alarm ⑦.8 Magnetic Contact ⑧ Safety Gate ⑨ Oxygen Display Unit ⑩ Emergency STOP Button ⑪ Electric Lock ⑫ Magnetic Contact ⑬ Block of 2 independent Oxygen Sensors ⑭ Driver Light Pan

There is an oxygen sensor located in the track-trailer to measure oxygen levels in the confined space.

When the LN₂ system is operational and the oxygen concentration in the trailer is below 18% (by volume) and if the track-trailer door is opened, the safety gate shown in Figure 1 will not be permitted to be opened and an audible siren will be activated and remain on to warn and prevent any personnel from entering the trailer.

Upon detection of the door opening and presence of low oxygen levels within the track-trailer, the following alarms are initiated:

1. Audio Oxygen alarm: An audible siren alerts the operator that it is unsafe to access the track-trailer. The audible alarm will stop once the O₂ levels are normal (safe for entry).
2. Visual Alarm: A red sign alerts the operator that it is unsafe to access the track-trailer. The sign will turn green once O₂ levels are normal (safe for entry).

An emergency stop switch is also provided, inside the track-trailer. A person trapped inside the track-trailer, when the door is accidentally closed and LN₂ injection is activated can push the lighted emergency stop switch and stop the flow of nitrogen into the compartment. Activation of the emergency switch will also alert the driver, through a flashing red LED outside the track-trailer.

There is a LED panel in the front end of the track-trailer to provide diagnostics on track-trailer performance. There is a LED visible from the driver's position to indicate health/status of the nitrogen cooling system.

Performance:

Technical information based on data collected on the new system is presented in Table 2 below.

Table 2 – natureFridge refrigeration system Vs diesel powered mechanical refrigeration system

NATUREFRIDGE SYSTEM		MECHANICAL SYSTEM	
NOISE LEVEL DURING OPERATION			
No Noise (<20 dB) PIEK certified since has noise level less than 58 dB required for night time operation.		Significant noise generation (>70 dB) Result in restriction of the system usage in cities at night (Noise ban at urban areas 10:00 p.m. - 6:00 a.m.)	
N₂ OR DIESEL CONSUMPTION DURING OPERATION, L/H			
Continuous Run	Cycle Run	Continuous Run	Economy
24	15	3.5	1.8
MAINTENANCE			
No moving parts therefore no regular service, only check procedure once in 12 month. Self-test is performed by the electronics regularly and in case of any failure sends signals (driver light, sound, display, by email to fleet manager)		Diesel refrigeration unit is complex system which requires constant service: engine service, compressor service, filter, pump changes, oil changes and refrigerant recharge	
GHG EMISSIONS			
No any GHG emissions during operation During LN ₂ production only electricity is consumed. In the majority of cases consumed LN ₂ is by-product of the air liquefaction process at LO ₂ and argon production. In some cases when LN ₂ demand is much higher than LN ₂ amount received as by product it is necessary to take into account foot print at electricity consumption for LN ₂ production (indirect CO ₂ emission per kWh is different in different countries)		Releases 2.94 kg CO ₂ per each liter of diesel fuel including extraction, refining, transport and combustion. Refrigerant leakage can add 5.1 tonnes eq CO ₂ /y to the total CO ₂ emissions resulting in 3.53 kg CO ₂ per each liter of diesel fuel	
CO₂ emission (kg per hour)			
3.74	2.34	12.36	6.35
CO₂ emissions (kg per year)			
8976	5616	29664	15240
Cooling capacity, cool down time and temperature fluctuations after door opening			
No limited cooling capacity in principal by adding more sprayers		Limited cooling capacity	
Cool down to -20C from 30C ambient in less than 30 minutes		Cool down to -20C from 30C ambient from 90 to 180 minutes	
Maintain a consistent temperature (-20C) throughout the trailer for more than 15 hours without top freezing and "hot spots" in the rear section of the trailers		Large fluctuations in temperature	
No defrosting procedure		Need defrosting every 6 hours when below freezing, consuming fuel for defrosting. Ice frosting leads to decreasing cooling efficiency and as the result no consistent temperature in the box. Large fluctuations in temperature require systems to work harder to retain temperature consuming additional amount of fuel	
Downtime			
Less downtimes		Higher system efficiency, reliability and durability (expected lifetime: virtually not limited)	
Higher system efficiency, reliability and durability (expected lifetime: virtually not limited)		Lower system efficiency, reliability and durability (expected lifetime: 7 years and less)	
Inert, food-safe nature of N ₂ ensures high food quality, less spoilage and dry up with natureFridge			
Safe cryogenic filling and easy operation. Less danger in the case of accident as LN ₂ is not flammable and nonexplosive as pressure in the fuel tank is low.			
Greater flexibility with multi-temperature zones of natureFridge – possibility to transport several low-volume goods in one trip saving transportation costs.			

Fig 2 represents natureFridge unit delivered for Nisa UK Company



Fig. 2
natureFridge refrigeration system installed in track

Cost and Economic Considerations:

As shown in Table. 3, total expenses per year for natureFridge system in comparison with diesel unit are lower even at today's decreasing diesel fuel prices not saying about 7 years diesel unit lifetime. Comparison was made for different modes of operation: continues run and periodic (cycle) run with intervals for natureFridge system; continues run and run in economy mode at economy fuel consumption for improved mechanical system.

Table 3 – Cost estimation for natureFridge system and Mechanical System

	natureFridge System		Mechanical System	
	OPERATION COST			
	Continues Run	Cycle Run	Continues Run	Economy
N ₂ or diesel consumption (liter per hour)	24	15	3.5	1.8
N ₂ or diesel Cost (per liter)	\$0.11*	\$0.11	\$0.8**	\$0.8
N ₂ or diesel Cost (per hour)	\$2.64	\$1.65	\$2.80	\$1.44
Total N ₂ or diesel cost per year (2400 operation hours)	\$6,336	\$3,960	\$6,720	\$2,59
MAINTENANCE COST				
	No moving parts therefore no regular service, only check procedure once in 12 months. Self-test is performed by the electronics regularly and in case of any failure sends signals (driver light, sound, display by email to fleet manager)		Diesel refrigeration unit is complex system which requires constant service: engine service, compressor service, filter, pump changes, oil changes and refrigerant recharge	
Maintenance cost per hour***	\$0.2	\$0.2	\$0.7-1	\$0.7-1
Total maintenance cost per year	\$480	\$480	\$2,400	\$2,400
Total expenses per year	\$6,816	\$4,440	\$9,120	\$4,990

As shown in Table. 4, fuel expenses for N₂ direct cryogenic refrigerated unit for rigid is 3-4 times cheaper than for N₂ indirect rigid cryogenic refrigerated unit and about 2 times cheaper than CO₂ indirect rigid cryogenic refrigerated unit, due to better refrigeration efficiency of the direct cooling method applied in natureFridge system in comparison with indirect heat exchanger cooling method and also due to better N₂ refrigeration efficiency in comparison with CO₂ refrigeration efficiency.

Table 4 – Cost estimation for natureFridge direct cryogenic system, indirect CO₂ system and indirect N₂ system

Vehicle	Average CO ₂ or N ₂ consumption Chilled, L/h	Average CO ₂ or N ₂ consumption Frozen, L/h	Average CO ₂ or N ₂ cost* Chilled, £/h	Average CO ₂ or N ₂ cost* Frozen, £/h
Indirect CO ₂	12.74	36.47	1.03	2.95
Indirect N ₂	40.50	60,70	3,15	4.55
Direct N ₂ natureFridge	11.00	18.00	0.77	1.26

Disclaimer:

The information presented here is provided by EcoFridge Production Company Ltd. The accuracy of the content and figures is the responsibility of the company and these have not been verified by the CCAC or UNEP.

* Estimation was done for the prices in UK: 0.11 USD/L for nitrogen = 0.11x0.63 =0.07£/L 0.1 £/kg for CO₂ (<http://www.grimsby.ac.uk/documents/defra/trns-casestudy.pdf>)

** Estimation was done for the average prices for red diesel in UK in 2015 =0, 8 USD <https://www.boilerjuice.com/red-diesel-prices/>

*** According to UK customer data scheduled service check of the natureFridge system is carried out twice per year (6000 operating hours per year) for about 3 hours each and costs 0.05 \$ per hour of check. No maintenance is needed for natureFridge.

Annex I

A note on GWP values used in this booklet

The GWP values included in the case studies in this booklet were provided by the enterprises that drafted the case studies. These have not been modified or standardised to the most recent values as it would have corresponding effects on the various calculations included in the case study.

Calculation of global warming potential (GWP) values of refrigerants is a complex issue. For the great majority of refrigerants there are a number of different values of GWP which could potentially be quoted for a specific refrigerant. This is due to a number of reasons. Firstly, these is variety of sources from which these values can be obtained; a commonly used source being the

Assessment Reports of the Intergovernmental Panel on Climate Change (IPCC). Secondly, the GWP values can be periodically updated based on the most recent research (however it should be noted that for reporting purposes, it can be necessary to use a particular version of GWP values, even if newer values are available). Thirdly, GWP values are calculated over different time horizons. Typically GWP values are quoted over a 100 year time horizon, although 20 and 500 year integrated values are also commonly provided.

The table below provides an easy reference to the various values quoted in the case studies and those provided by IPCC Assessment Reports for all the refrigerants included in this compilation.

Name/Refrigerant Designation	GWP value quoted in case study	GWP VALUES FOR 100-YEAR TIME HORIZON		
		2nd IPCC Assessment Report (1995)	4th IPCC Assessment Report (2007)	5th IPCC Assessment Report (2014)
HFC-134a	1430	1300	1430	1300
HCFC-22	1780	1500	1810	1760
HFC-404A	3900, 3922	3260	3922	3900*
HFC-507A	3985	3300	3985	4000*
HFO-1234ze	6	-	-	<1*
R-449A (Opteon™ XP40)	1397	-	-	1300*
R-450A (Solstice® N13)	547	-	-	550*

* As quoted in the TEAP March 2016: Decision XXVII/4 Task Force Report - Further Information on Alternatives to Ozone-Depleting Substances

The GWP values of ammonia (R-717) carbon dioxide (R- 744, CO₂) and propane (R-290) are 0, 1 and 5¹⁵ respectively.



CLIMATE & CLEAN AIR COALITION

TO REDUCE SHORT-LIVED
CLIMATE POLLUTANTS

This booklet presents a series of case studies on lower-GWP energy efficient alternatives and technologies in the commercial and transport refrigeration sectors. It is an information resource intended to assist relevant decision makers, especially those in developing countries, in selecting the most appropriate climate-friendly alternatives. The publication provides an update to the first compilation of case studies which was published by UNEP DTIE OzonAction/CCAC in 2014. It provides a number of new commercial refrigeration case studies and case studies from the transport refrigeration sector, including alternatives not previously considered. All the case studies from the first compilation are maintained.

For more information, contact;

OzonAction

**United Nations Environment Programme
Division of Technology, Industry and
Economics**

1, rue Miollis, Building VII

75015 Paris, France

Tel: +33 1 44 37 14 50

Fax: +33 1 44 37 14 74

Email: ozonaction@unep.org

www.unep.org/ozonaction/

**Climate and Clean Air Coalition to Reduce
Short-Lived Climate Pollutants (CCAC)**

Secretariat

United Nations Environment Programme

Division of Technology, Industry and

Economics

1, rue Miollis, Building VII

75015 Paris, France

Email: ccac_secretariat@unep.org

Telephone: +33 1 44 37 14 50

Fax: +33 1 44 37 14 74

Email: ccac_secretariat@unep.org

www.unep.org/ccac
